



亿利达
YILIDA METAL MESH

EXPANDED METAL

ENGINEERING



ADVANCED EXPANDED METAL
MANUFACTURER & SOLUTION
PROVIDER

YILIDA

– NEVER STOP INNOVATING

ENGINEERING



Expanded metal is a one-piece mesh material made of solid steel plate after slitting and stretching. It is sturdy and durable and offers excellent load capacity and anti-skid performance. As a result, it can create safe working conditions for pedestrians and equipment. It is widely used in walkways, stair treads, greenhouse benches, trailer ramps, etc. We can provide custom expanded metal solutions for your specific engineering projects to meet your application demand.

Walkway

Expanded metal walkway offers high load capacity and excellent anti-skid performance. So, it is widely used in various industries to provide a safe passage for construction, transportation, maintenance activities, for example, overpass walkway, oil and gas platform, offshore platform, solar panel construction, roof platform systems, etc.



We can supply aluminum, carbon steel, stainless steel and other expanded metal walkways. They are generally have galvanized or powdered coated treated to enhance its corrosion resistance and extend its service life.

Features

- **Excellent anti-skid performance.** Raised mesh surface enhances the friction between underfoot and walkway contact area to prevent pedestrians from slipping and ensure walking security.
- **High load capacity.** Made of 3 mm – 8 mm thick steel plates that are thicker than standard expanded metal, no welding joint. Besides, large strand width and opening size also deliver higher load capacity.
- **Corrosion resistance.** Galvanized or powder coated surface makes it have excellent resistant to acids and bases.
- **Easy maintenance.** Opening design makes the dirt, rain and snow fall off smoothly, reduce the frequency of cleaning and maintenance.

Category

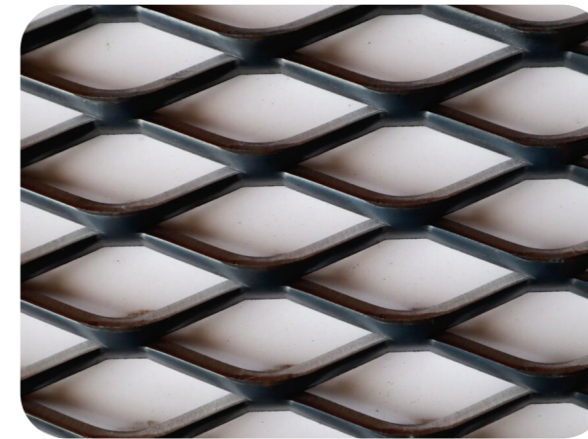

Diamond

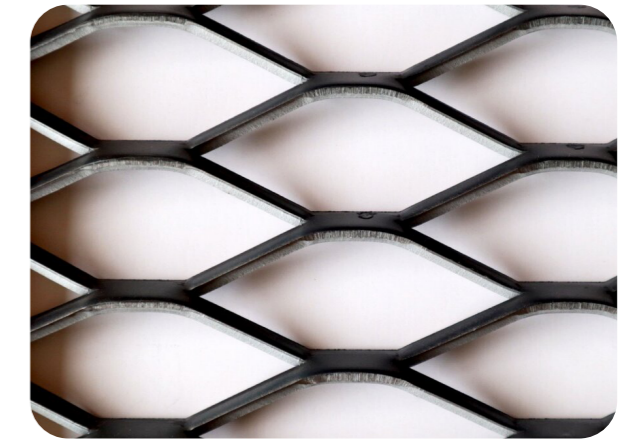

Hexagonal

Specification

Material	Opening Size (mm)		Strand (mm)		Weight (kg/m ²)
	SWD	LWD	Thickness	Strand Width	
Carbon steel, galvanized steel, aluminum	30	75	3.0	7.0	10.70
	34	76	4.0	5.0	8.80
	30	75	5.0	7.5	23.00
	42	135	5.0	8.0	14.05
	30	75	5.0	10.5	27.00
	45	135	5.0	11.0	19.00

Gallery



Surface platform walkway



Overhead pipe walkway



Industrial platform walkway

Stair Treads

Expanded metal stair treads have excellent anti-skid performance and high load capacity, and are very suitable for moving stairs, stationary stairs and spiral stairs in project construction. We can provide expanded metal stair treads perfect match up with your application environments to provide safety protection for your construction workers.

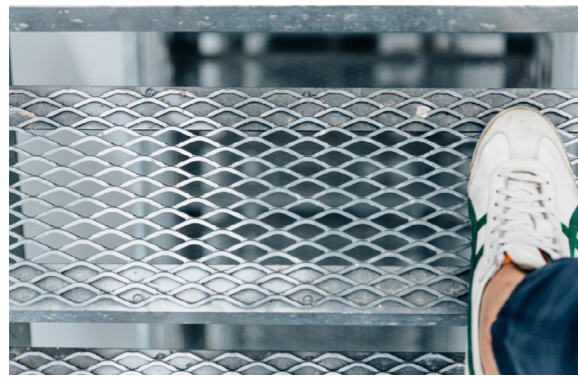

- Excellent anti-skid performance makes pedestrians free from falling risks arising from slipping.
- Rigid structure offers high load capacity and strong, stable support.
- Diamond openings help snow, water, grease and fluid to drain out.
- Unique surface structure can effectively avoid dazzling feeling when people looking down from a high place.

Specification

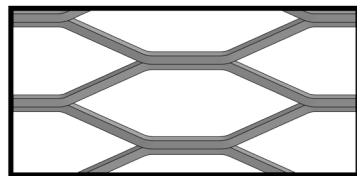

2.0 lb, 3.0 lb, 4.0 lb, 5.0 lb, 6.25 lb, 7.0 lb

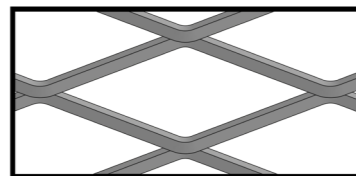

3.14 lb

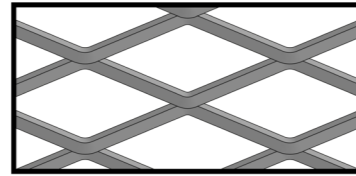

4.27 lb

Carbon Steel Expanded Metal Stair Treads

Material	Weight (lbs./ft ²)	Opening Size (Inch)		Strand (Inch)		Open Area
		SWD	LWD	Width	Thickness	
Carbon steel	2.00	1.33	5.33	0.24	0.14	77%
	3.00	1.33	5.33	0.26	0.18	60%
	3.14	2.00	6.00	0.31	0.25	69%
	4.00	1.33	5.33	0.30	0.22	55%
	4.27	1.41	4.00	0.30	0.25	58%
	5.00	1.33	5.33	0.33	0.25	50%
	6.25	1.41	5.33	0.35	0.31	50%
	7.00	1.41	5.33	0.39	0.32	45%

Stainless Steel Expanded Metal Stair Treads

Material	Weight (lbs./ft ²)	Opening Size (Inch)		Strand (Inch)		Open Area
		SWD	LWD	Width	Thickness	
Stainless steel	3.32	2.00	6.00	0.31	0.25	69%
	4.25	1.41	4.00	0.30	0.25	58%

Aluminum Expanded Metal Stair Treads

Material	Weight (lbs./ft ²)	Opening Size (Inch)		Strand (Inch)		Open Area
		SWD	LWD	Width	Thickness	
Aluminum	2.00	1.33	5.33	0.39	0.25	48%

Load Capacity Diagram

The load capacity of expanded metal stair treads is mainly reflected in 2 aspects of transverse uniform load and concentrated load. Our expanded metal stair treads comply with EMMA 557-15 standard requirements.

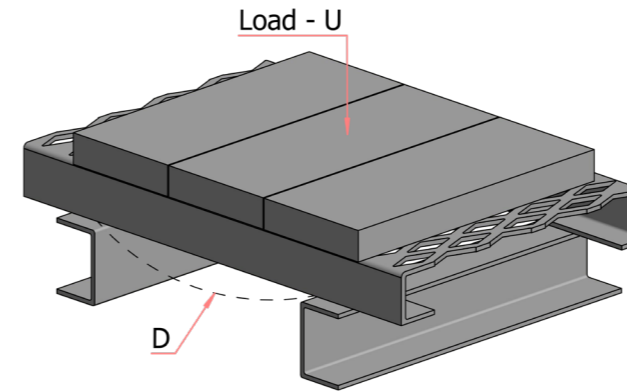

Uniform load and deflection diagram

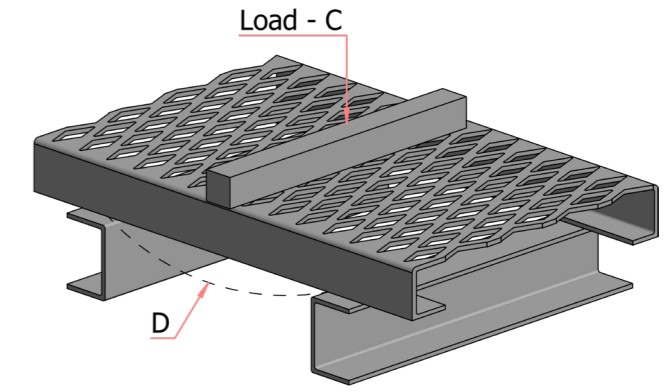

Concentrated load and deflection diagram

Carbon Steel Expanded Metal Stair Tread Concentrated Load & Deflection Table

Style (lbs./ft ²)	Concentrated Load C (lb./ft.) & Deflection D (in.)	24-Inch Span	36-Inch Span
3.0#	C	274	126
	D	0.25	0.25
3.14#	C	340	117
	D	0.25	0.25
4.0#	C	468	201
	D	0.25	0.25
4.27#	C	419	196
	D	0.25	0.25

Aluminum Expanded Metal Stair Tread Concentrated Load & Deflection Table

Style (lbs./ft ²)	Concentrated Load C (lb./ft.) & Deflection D (in.)	24-Inch Span	36-Inch Span
2.0#	C	320	136
	D	0.25	0.25

Notes:

- The allowable tolerance for weight per square foot is $\pm 5\%$.
- Both ends of the tested expanded metal stair tread have been welded to a fixed metal frame.

Gallery



Spiral stairs



Stationary stairs

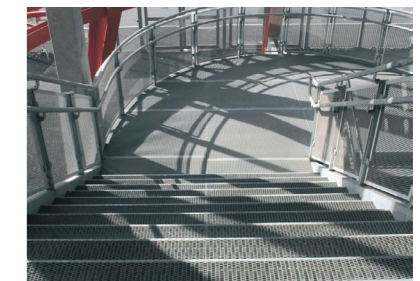

Industrial platform stairs



Greenhouse Benches

In the greenhouse planting industry, expanded metal greenhouse benches are very popular and provide a strong, solid support for potted plants. Expanded metal for greenhouse benches is generally flattened expanded metal to provide a flat surface and prevent potted plants from falling off. In addition, uniform opening allows the free passage of air and sunlight, creating a sound growing environment for plants in the greenhouse.



- Uniform opening allows the free passage of air and sunlight, creating a superior growing environment for plants.
- Unique one-piece construction makes it have higher load capacity than ordinary welded mesh.
- Large open areas contribute to draining out excessive water after irrigation, keeping the greenhouse bench clean and dry.
- Hot dip galvanized surface offers excellent corrosion resistance and enjoys a long lifespan.

Specification

Material	carbon steel, stainless steel
Hole pattern	diamond
Opening size	23 mm × 50 mm
Thickness	2 mm – 3 mm
Open area	76%–79%
Load capacity	55–65 kg/m ²
Surface treatment	hot dip galvanized, zinc content 500 g/m ²

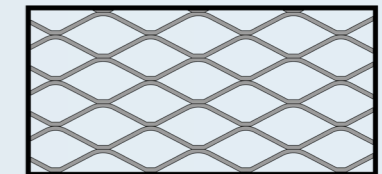

3/4" #13 Flattened

Gallery



EXPANDED METAL

ADVANCED EXPANDED METAL
MANUFACTURER
& SOLUTION PROVIDER

Anping Yilida Metal Wire Mesh Co., Ltd

Address: Wire Mesh Development Zone, Anping County, Hengshui City, Hebei Province, China. 053600

Tel: +86-13932824722

Whatsapp: +86-311-89948200

Email: inquiry@wiremesh-yld.cn

<https://www.yld-wiremesh.com>

