



亿利达
YILIDA METAL MESH

EXPANDED METAL

CATALOG
2022

ADVANCED EXPANDED METAL
MANUFACTURER & SOLUTION
PROVIDER

YILIDA

– NEVER STOP INNOVATING

CONTENTS

03

About Yilida

- Company Profile
- Our History
- Strong Capacity
- Quality Control

10

Products

- Standard Expanded Metal
- Flattened Expanded Metal
- Expanded Metal Grating
- Small Hole Expanded Metal
- Decorative Expanded Metal

24

Application

- Security & Protection
 - Security Fence
 - Machine Guards

- Construction
 - DVA Mesh
 - Expanded Metal Lath
 - Brick Reinforcement Mesh
 - Expanded Gutter Guards
 - Expanded Metal Bolt Boxes
 - Expanded Metal Drywall Security Mesh

- Engineering
 - Walkway
 - Stair Treads
 - Greenhouse Benches

- Decoration
 - Facade
 - Ceiling
 - Sunshade
 - Interior Decoration
 - Handrails

- Filtration
- Automobile
- More

56

Made-to-Order

YILIDA

“

Advanced Expanded Metal
Manufacturer & Solution Provider”

”



Mr. Song Tieling
National Standard Drafters



Established in 1984, Yilida Metal Wire Mesh Co., Ltd., specialized in expanded metal development and production, is a leading expanded metal manufacturer and custom solution provider. Over the past 30 years, we have accumulated rich experience in the expanded metal production and solution development. So far, our expanded metal products have been widely used in safety protection, industrial platform, construction, building decoration, filtration and other fields.

We will continue to push the boundaries, develop new products and applications, provide more solutions for different applications and meet various engineering needs.

To assist the development of the industry, Mr. Song Tieling, chairman of Yilida, and his team actively offered suggestions and became one of the important drafting enterprise in the new national standard (GB/T 33275-2016) by summarizing the experience and data accumulated in the past, making contribution to promoting the standardized production of the industry.

OUR HISTORY

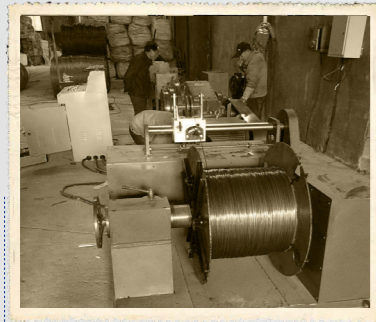

1984

Started a startup and bought wire drawing machines. Mr. Song Tieling started his business career, he built a factory of about 200 m² and bought several wire drawing machines. The main business was to produce steel wires for weaving factory.



1992

Bought the first expanded metal machine. Mr. Song purchased the first expanded metal production machine to start transform the business from steel wires to expanded metal mesh for native market and established the foundation for the future development.



2003

Expanded the scale of our enterprise. The government promoted the development of Wire Mesh industry and established the industrial zone. Yilida purchased 8000 m² land for enterprise production and development. At the same year, Yilida improved the QC system and established the R&D department.

2008

Independently developed heavy punching equipment. Yilida's annual output exceeded 15000 tons. Besides, Yilida independently developed heavy punching equipment and leveling, cutting and pressing equipment for subsequent processing, to meet the customized needs of customers for different applications.



2016

Took part in the expanded metal national standard draft. Mr. Song Tieling, chairman of Yilida, was invited to take part in the expanded metal national standard (GB/T 33275-2016) drafting by virtue of his many years of research and practical production experience in expanded metal, making a huge contribution to promoting the standardized production of the industry.

2017

Enlarged the factory area and introduced advanced equipment. In order to meet the larger development needs of the enterprise, Yilida purchased 32,000 m² land for the factory scale expansion and construction. In addition, Yilida introduced many expanded metal production machines, cutting machines, leveling machines and other production equipment, to better meet our customers' demands for large orders.

1984

1989

1992

1998

2003

2005

2008

2011

2016

2017

2022



1989

Ran a wire mesh store in Panjin. The Anping wire mesh was gradually accepted by international market and the application was continuously developed. Mr. Song run a store at Panjin City. The main business was to sell steel wires and imported wire meshes at local market.



1998

Established Tieling Expanded Metal Factory. With the continuous development of the business and continuous increase of orders, Mr. Song established "Tieling Expanded Metal Factory" and purchased 5 expanded metal production machines to satisfy different sizes and requirements of expanded metal. The products obtained a good reputation for quality.



2005

Won import and export rights. Registered Yilida Metal Wire Mesh Co., Ltd. with import and export rights, and get continuous export orders. The company continued to improve the equipment and technology to meet the quality requirements of domestic and foreign customers.

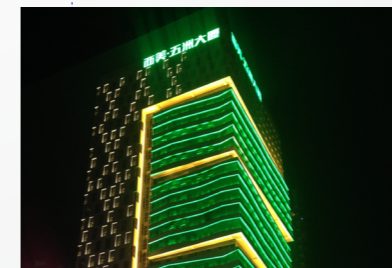

2011

Founded an office in Shijiazhuang. With the continuous expansion of our business, our products are not only sold at home, but also exported to South America, North America, Europe, Middle East and Southeast Asia, etc. Our company was listed as a star enterprise by the government. In the same year, Yilida set up an office in Shijiazhuang, the capital of Hebei Province, to attract more talents.

2022

Remain committed to R&D and innovation. So far, Yilida has owned 25 production lines with an annual output of 35,000 tons. Our expanded metal products have been widely used in many industries such as safety protection, building decoration, engineering construction, filtration and automobile. However, we do not stop moving forward, we still work hard to fight on the journey of R&D and innovation.



STRONG CAPACITY

With a factory area of 34,000 m², Yilida has state-of-the-art production equipment and a series of independently improved equipment to produce over 1,000 kinds of expanded metal products. With an annual output of up to 35,000 tons, our expanded metal SWD (Short Way Dimension) ranges from 2 mm to 150 mm and strand thickness ranges from 0.35 mm to 12 mm. So, Yilida can complete our customers' small and large orders flexibly and efficiently.



13
R&D Staff

Continue to develop expanded metal products to suit to various application environments.



25
Production Lines

Dedicated to various expanded metal production and efficient order delivery.

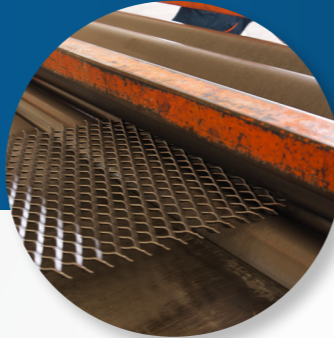

50+
Production Equipment

Meet different expanded metal manufacturing requirements.



100+
Skilled Workers

Get familiar with expanded metal production process and can correct errors found in the production process.



34000+m²
Factory Area

Large factory area provides a precondition for large scale production.



35000T
Annual Output

Annual output increase year by year meets ever-growing order demands.

10
Heavy Duty Expanded Metal Machines

The machines are used to produce thicker expanded metal products that are used in applications requiring high load bearing capacities, such as platforms, pedals, etc.

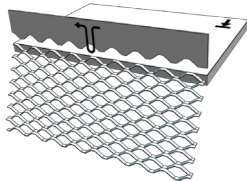

12
Small Hole Expanded Metal Machines

The machine is used to produce up to 0.35 mm thickness expanded metal products that are used as filter screens, window guards, leaf guards, insect guards, etc.

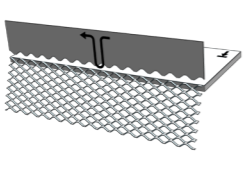

7
Flattening Machines

The machine flattens a standard expanded metal into flattened expanded metal with a cold roll, leaving a uniform, smooth and flat surface.

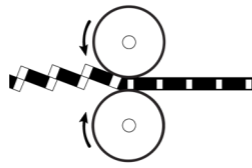

10
Leveling Machines

The expanded metal gives a flat, burr-free surface after passing leveling machine. We can also level expanded metal products with a larger width.

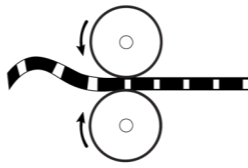

8
Shearing Machines

Our shearing machines precisely cut the expanded metal with a thickness of 0.35–12 mm into desired sizes, and offer minimal cutting tolerances.



4
Bending Machines

Our bending machines can easily bend the edges of the expanded metal to better fit the practical applications, such as pedals, ceilings and fences.

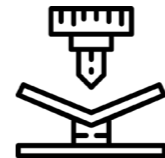

500 +
Moulds

We have independently developed over 500 kinds of moulds to produce expanded metal products in various hole patterns, such as diamond and Gothic.

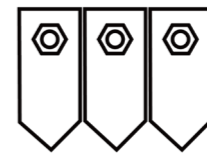

∞
Various Fabrication Equipment

Our welding, forming, spraying and other fabrication equipment can meet customers' higher requirements for durability and attractiveness.

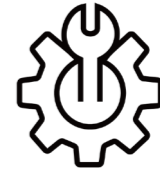



QUALITY CONTROL

Product quality is always what our customers and ourselves concern most. We work hard to achieve maximum customer satisfaction by providing our customers with superb expanded metal products. We have established a complete set of quality control system and passed ISO 9001 and SGS certification. Our dedicated quality analyzer team implement strict quality control in every phase of production from raw material purchasing, during the production, finished product packaging and final perfect delivery.

ISO 9001 Certificate



SGS Certificate

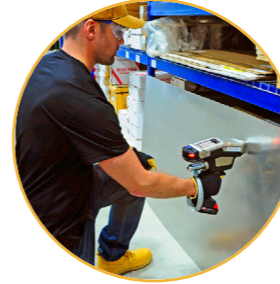

Strict Quality Control Starts from the Sources

Our raw material steel plates come from Baosteel, Shougang Group and other well-known suppliers. Besides, our quality inspector will test chemical composite, sizes and other relevant items when receiving the raw materials to ensure the raw materials received meet or even exceed corresponding quality standards and requirements.



Real-Time Production Process Monitoring

During the production process, our technicians carry out real-time monitoring on punching, flattening, shearing and leveling links. On the one hand, we can test product quality at any time; on the other hand, we can find the deficiencies in the production process and constantly improve our production line and product quality.

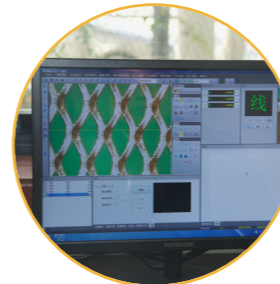

Independent Laboratory Testing

We have independent laboratory to perform raw material chemical composite analyze, mesh opening testing and product performance testing to ensure our products comply with manufacturing tolerances and have best load bearing capacity and corrosion resistance. Besides, we can supply corresponding test reports to make you have confident in using our products in your specific applications.

Well-Designed Package

According to the chemical and physical properties of the products, we use waterproof, moisture-proof and breakage-proof materials for packaging to avoid product damage during transportation. In addition, we can also provide customized packaging according to customer's specific requirements to meet the special needs of different customers.



STANDARD EXPANDED METAL

Standard expanded metal, also known as raised expanded metal, is produced by simultaneously slitting and stretching metal sheets or coils. It features a surface of raised diamond-shaped openings. In addition, raised strands form an angle to the original plane of the solid sheet, adding additional strength and rigidity. It also delivers great anti-skid performance. As a result, it has virtually endless applications including road fences, platforms and stair treads, machine guarding, etc.

We can supply a large assortment of standard expanded metal products made of high quality materials including carbon steel, galvanized steel and aluminum, to ensure the best performance and durability of the products. Besides, we can work with you to develop custom expanded metal solutions to fit your specific application through deep communication.



Features

- Uniform mesh opening allows light, heat and air to flow freely.
- It has a lighter weight and a more rigid structure compared with the material of the same size.
- Three-dimensional structure offers great anti-skid performance.
- One-piece construction expanded metal material, no welding joint and the edge is not easy to loose.
- In the production process, no material is wasted, economical and environmental-friendly, saving raw materials.

Available Materials

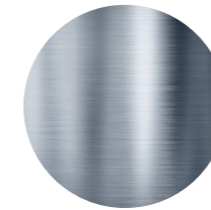

Carbon Steel

It is one of the most cost-effective metal materials with good rigidity and great durability. It is often galvanized or powder coated to enhance its corrosion resistance. It is widely used in support structures.

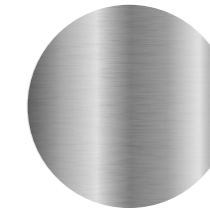

Galvanized Steel

It is a type of steel that has been galvanized to enhance its corrosion resistance and anti-aging performance. It is widely used in various industrial applications including walkway gratings, stair treads, greenhouse benches, etc.

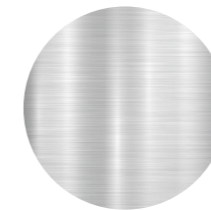

Stainless Steel

It has excellent corrosion resistant, impact resistant and fireproof characteristics. It has a bright, maintenance-free and easy to spray surface. It is widely used in various industrial and building decoration applications.

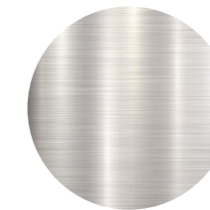

Aluminum

It features easy to form, high strength-to-weight ratio, great corrosion resistance and fire resistance. The surface is usually anodized or PVDF coated. It is an ideal material for architectural decoration applications.

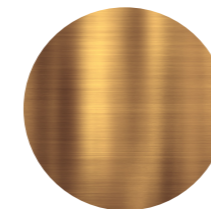

Copper

It is a safe and recyclable metal material with good softness, ductility, thermal and electrical conductivity. It is widely used in electrical appliances heat dissipation, Faraday cage, architectural decoration applications, etc.

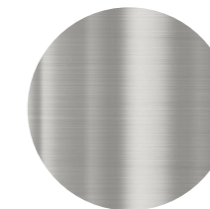

Nickel

It is a silvery-white metal material with good magnetic properties, high ductility and electrical conductivity. In addition, it is not easily oxidized in air and is often used to make special steels and other alloys, catalysts, etc.

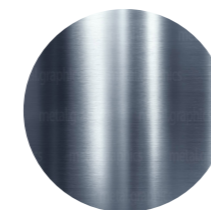

Titanium

It has a low density and the highest strength-to-weight ratio among all metallic elements. Besides, it has the highest corrosion resistance in seawater and chlorine. It is non-magnetic and has low thermal and electrical properties.

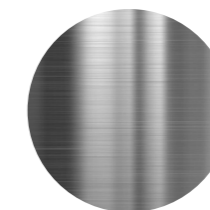

Other Alloy

We also supply other alloy materials with higher rigidity, corrosion resistance, and other special properties for expanded metal production to suit to harsh working conditions and meet your special project requirements.

Hole Patterns

We can develop new moulds according to customers' requirements and supply expanded metal products with custom hole patterns.

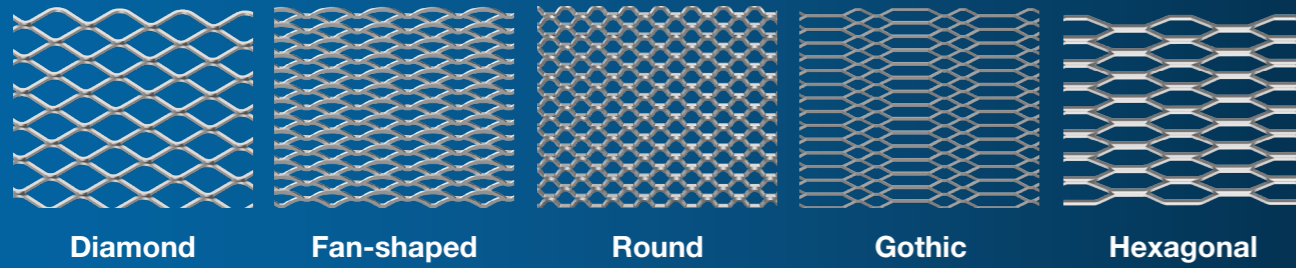

Structure

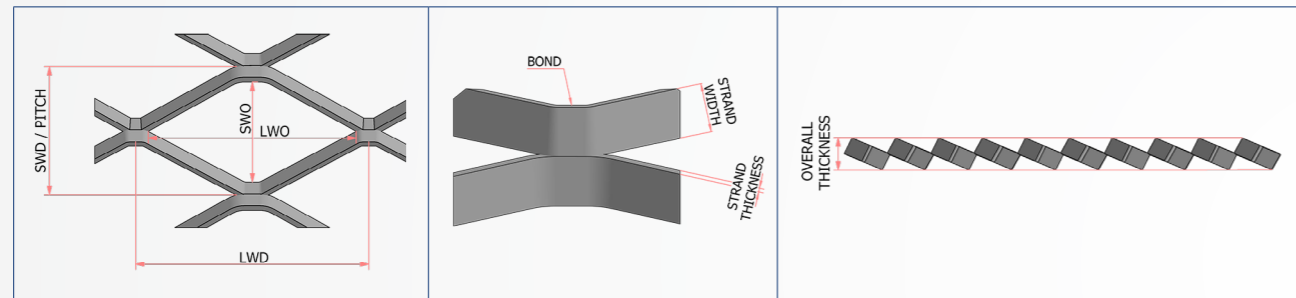

Specifications of Carbon Steel Standard Expanded Metal

Style	Minimum Thickness (inches) ^A	Nominal Weight in lbs./100 Sq. Ft. ^B	Design Size (inches) ^C		Opening Size (inches) ^C		Strand Size (inches)		Overall Thickness (inches)	Open Area
			SWD	LWD	SWO	LWO	Width	Thickness		
¼"-#20	0.032	85	0.250	1.00	0.157	0.718	0.072	0.036	0.146	42%
¼"-#18	0.042	113	0.250	1.00	0.146	0.718	0.072	0.048	0.151	42%
½"-#20	0.032	42	0.500	1.20	0.407	0.938	0.072	0.036	0.146	71%
½"-#18	0.042	69	0.500	1.20	0.382	0.938	0.088	0.048	0.180	65%
½"-#16	0.053	85	0.500	1.20	0.372	0.938	0.087	0.060	0.183	65%
½"-#13	0.083	141	0.500	1.20	0.337	0.938	0.096	0.090	0.212	62%
¾"-#16	0.053	54	0.923	2.00	0.783	1.750	0.101	0.060	0.208	78%
¾"-#13	0.083	77	0.923	2.00	0.760	1.688	0.096	0.090	0.212	79%
¾"-#10	0.083	117	0.923	2.00	0.718	1.625	0.144	0.092	0.300	69%
¾"-#9	0.127	178	0.923	2.00	0.675	1.562	0.150	0.134	0.329	67%
1"-#16	0.053	43	1.00	2.40	0.872	2.062	0.087	0.060	0.183	83%
1½"-#18	0.042	20	1.33	3.00	1.229	2.625	0.068	0.048	0.144	90%
1½"-#16	0.053	40	1.33	3.00	1.184	2.625	0.108	0.060	0.221	84%
1½"-#13	0.083	58	1.33	3.00	1.160	2.500	0.105	0.090	0.228	84%
1½"-#10	0.083	76	1.33	3.00	1.132	2.500	0.138	0.090	0.288	79%
1½"-#9	0.127	119	1.33	3.00	1.087	2.375	0.144	0.134	0.318	78%
1½"-#6	0.184	247	1.33	3.00	0.979	2.313	0.203	0.198	0.452	69%
2"-#10	0.083	65	1.85	4.00	1.630	3.438	0.164	0.090	0.335	82%
2"-#9	0.127	88	1.85	4.00	1.603	3.375	0.149	0.134	0.327	84%

*A The minimum thickness is absolute, not subject to minus variation.
 *B A variation in weight per square ft. of ±10 % is permissible, based on the weight of any sheet or bundle.
 *C A tolerance of ±10 % is permitted in dimensions, center to center.

Specifications of Stainless Steel Standard Expanded Metal

Style	Minimum Thickness (inches) ^A	Nominal Weight in lbs./100 Sq. Ft. ^B	Design Size (inches) ^C		Opening Size (inches) ^C		Strand Size (inches)		Overall Thickness (inches)	Open Area
			SWD	LWD	SWO	LWO	Width	Thickness		
½"-#18	0.044	69	0.500	1.20	0.383	0.937	0.087	0.048	0.178	65%
½"-#16	0.055	87	0.500	1.20	0.372	0.937	0.087	0.060	0.183	65%
½"-#13	0.085	143	0.500	1.20	0.418	0.876	0.096	0.090	0.254	62%
¾"-#18	0.044	46	0.923	2.00	0.790	1.750	0.106	0.048	0.212	77%
¾"-#16	0.055	57	0.923	2.00	0.779	1.760	0.106	0.060	0.217	77%
¾"-#13	0.085	87	0.923	2.00	0.751	1.687	0.107	0.090	0.232	77%
¾"-#9	0.128	194	0.923	2.00	0.666	1.562	0.160	0.135	0.347	65%
1½"-#16	0.055	43	1.33	3.00	1.179	2.750	0.115	0.060	0.234	83%
1½"-#13	0.085	65	1.33	3.00	1.152	2.625	0.115	0.090	0.246	83%
1½"-#9	0.128	130	1.33	3.00	1.077	2.500	0.155	0.135	0.338	77%

*A The minimum thickness is absolute, not subject to minus variation.
 *B A variation in weight per square ft. of ±10 % is permissible, based on the weight of any sheet or bundle.
 *C A tolerance of ±10 % is permitted in dimensions, center to center.

Specifications of Aluminum Standard Expanded Metal

Style	Minimum Thickness (inches) ^A	Nominal Weight in lbs./100 Sq. Ft. ^B	Design Size (inches) ^C		Opening Size (inches) ^C		Strand Size (inches)		Overall Thickness (inches)	Open Area
			SWD	LWD	SWO	LWO	Width	Thickness		
½"-#050	0.045	26	0.500	1.20	0.376	0.937	0.093	0.050	0.190	63%
½"-#080	0.074	43	0.500	1.20	0.346	0.937	0.096	0.080	0.208	62%
¾"-#050	0.045	17	0.923	2.00	0.786	1.750	0.109	0.050	0.219	76%
¾"-#080 (Lt)	0.074	31	0.923	2.00	0.741	1.680	0.129	0.080	0.268	72%
¾"-#080 (HVY)	0.074	40	0.923	2.00	0.711	1.680	0.165	0.080	0.333	64%
¾"-#125	0.118	64	0.923	2.00	0.667	1.680	0.169	0.125	0.359	63%
1½"-#080	0.074	22	1.33	3.00	1.149	2.500	0.128	0.080	0.266	81%
1½"-#125	0.118	43	1.33	3.00	1.080	2.500	0.162	0.125	0.346	76%

*A The minimum thickness is absolute, not subject to minus variation.
 *B A variation in weight per square ft. of ±10 % is permissible, based on the weight of any sheet or bundle.
 *C A tolerance of ±10 % is permitted in dimensions, center to center.

FLATTENED EXPANDED METAL

Flattened expanded metal is what results when standard expanded metal is put through a cold rolling steel mill to flatten the expanded metal out. During the rolling process, the expanded metal becomes thinner and longer. As a result, flattened expanded metal is flatter and lighter. In actual applications, flattened expanded metal is mostly used in applications requiring lightweight, flexible expanded metal that offers certain strength and durability, such as shelves, window guards, greenhouse benches and dry safety walls.

Our flattened expanded metal products come in a variety of high quality metal materials, hole patterns and mesh openings to ensure they are perfectly suited to different industrial applications.

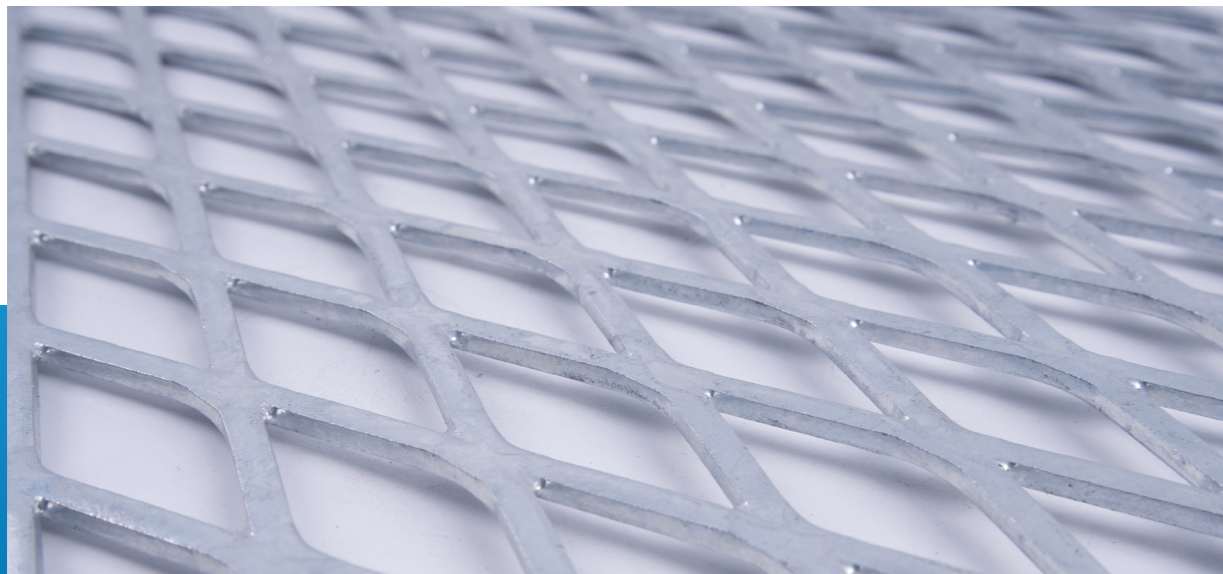

Features

- Flat, smooth surface, avoid scratch injuries.
- Lightweight, high strength and rigidity.
- Economical, durable, wide range of application.
- Easy to install and maintain.

Available Materials

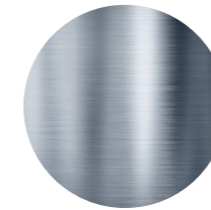

Carbon Steel

It is one of the most cost-effective metal materials with good rigidity and great durability. It is often galvanized or powder coated to enhance its corrosion resistance. It is widely used in support structures.

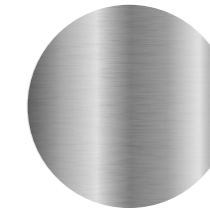

Galvanized Steel

It is a type of steel that has been galvanized to enhance its corrosion resistance and anti-aging performance. It is widely used in various industrial applications including walkway gratings, stair treads, greenhouse benches, etc.

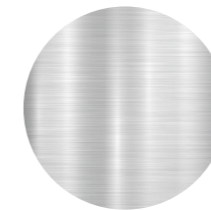

Stainless Steel

It has excellent corrosion resistant, impact resistant and fireproof characteristics. It has a bright, maintenance-free and easy to spray surface. It is widely used in various industrial and building decoration applications.

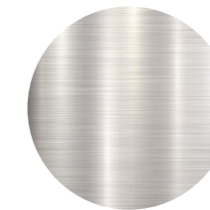

Aluminum

It features easy to form, high strength-to-weight ratio, great corrosion resistance and fire resistance. The surface is usually anodized or PVDF coated. It is an ideal material for architectural decoration applications.

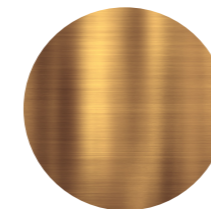

Copper

It is a safe and recyclable metal material with good softness, ductility, thermal and electrical conductivity. It is widely used in electrical appliances heat dissipation, Faraday cage, architectural decoration applications, etc.

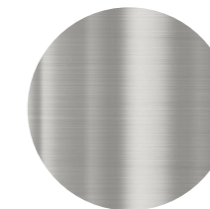

Nickel

It is a silvery-white metal material with good magnetic properties, high ductility and electrical conductivity. In addition, it is not easily oxidized in air and is often used to make special steels and other alloys, catalysts, etc.

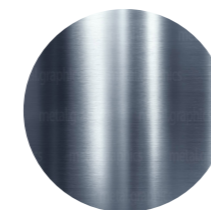

Titanium

It has a low density and the highest strength-to-weight ratio among all metallic elements. Besides, it has the highest corrosion resistance in seawater and chlorine. It is non-magnetic and has low thermal and electrical properties.

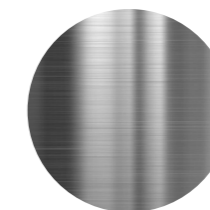

Other Alloy

We also supply other alloy materials with higher rigidity, corrosion resistance, and other special properties for expanded metal production to suit to harsh working conditions and meet your special project requirements.

Structure

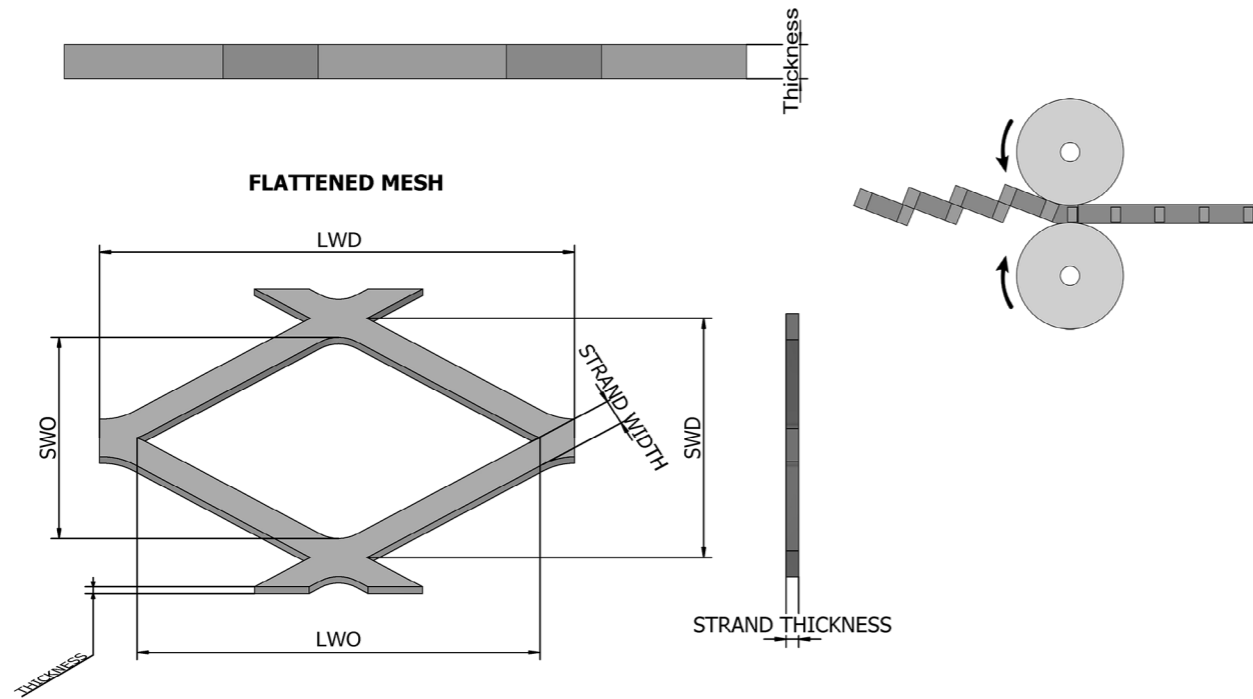

Specifications of Stainless Steel Flattened Expanded Metal

Style	Minimum Thickness (inches) ^A	Nominal Weight in lbs./100 Sq. Ft. ^B	Design Size (inches) ^C		Opening Size (inches) ^C		Strand Size (inches)		Overall Thickness (inches)	Open Area
			SWD	LWD	SWO	LWO	Width	Thickness		
½"-#18	0.037	66	0.500	1.26	0.304	1.000	0.098	0.041	0.041	61%
½"-#16	0.047	84	0.500	1.26	0.302	1.000	0.099	0.051	0.051	60%
½"-#13	0.072	136	0.500	1.26	0.236	0.915	0.107	0.076	0.076	57%
¾"-#18	0.037	43	0.923	2.10	0.687	1.812	0.118	0.041	0.041	74%
¾"-#16	0.047	54	0.923	2.10	0.687	1.812	0.118	0.051	0.051	74%
¾"-#13	0.072	83	0.923	2.10	0.683	1.750	0.120	0.076	0.076	74%
¾"-#9	0.108	185	0.923	2.10	0.593	1.687	0.179	0.114	0.114	61%
1½"-#16	0.047	41	1.33	3.15	1.074	2.750	0.128	0.051	0.051	81%
1½"-#13	0.072	62	1.33	3.15	1.070	2.625	0.130	0.076	0.076	80%
1½"-#9	0.108	124	1.33	3.15	0.960	2.625	0.174	0.114	0.114	74%

*A The minimum thickness is absolute, not subject to minus variation.

*B A variation in weight per square ft. of ±10 % is permissible, based on the weight of any sheet or bundle.

*C A tolerance of ±10 % is permitted in dimensions, center to center.

Specifications of Carbon Steel Flattened Expanded Metal

Style	Minimum Thickness (inches) ^A	Nominal Weight in lbs./100 Sq. Ft. ^B	Design Size (inches) ^C		Opening Size (inches) ^C		Strand Size (inches)		Overall Thickness (inches)	Open Area
			SWD	LWD	SWO	LWO	Width	Thickness		
¼"-#20	0.026	74	0.250	1.05	0.092	0.715	0.079	0.029	0.029	37%
¼"-#18	0.034	100	0.250	1.05	0.090	0.715	0.080	0.038	0.038	36%
½"-#20	0.026	37	0.500	1.26	0.342	1.000	0.079	0.029	0.029	68%
½"-#18	0.034	61	0.500	1.26	0.306	1.000	0.097	0.038	0.038	61%
½"-#16	0.043	77	0.500	1.26	0.304	1.000	0.098	0.048	0.048	61%
½"-#13	0.066	126	0.500	1.26	0.286	1.000	0.107	0.072	0.072	57%
¾"-#16	0.043	47	0.923	2.10	0.701	1.750	0.111	0.048	0.048	76%
¾"-#14	0.054	56	0.923	2.10	0.713	1.760	0.105	0.060	0.060	77%
¾"-#13	0.066	67	0.923	2.10	0.711	1.781	0.106	0.072	0.072	67%
¾"-#10	0.066	102	0.923	2.10	0.603	1.755	0.160	0.072	0.072	65%
¾"-#9	0.101	157	0.923	2.10	0.593	1.688	0.165	0.108	0.108	64%
1"-#16	0.043	38	1.000	2.52	0.804	2.250	0.098	0.048	0.048	80%
1½"-#16	0.043	35	1.330	3.15	1.092	2.750	0.119	0.048	0.048	82%
1½"-#14	0.054	43	1.330	3.15	1.098	2.750	0.116	0.060	0.060	83%
1½"-#13	0.066	51	1.330	3.15	1.098	2.750	0.116	0.072	0.072	83%
1½"-#9	0.101	105	1.330	3.15	1.014	2.563	0.158	0.108	0.108	76%

*A The minimum thickness is absolute, not subject to minus variation.

*B A variation in weight per square ft. of ±10 % is permissible, based on the weight of any sheet or bundle.

*C A tolerance of ±10 % is permitted in dimensions, center to center.

Specifications of Aluminum Flattened Expanded Metal

Style	Minimum Thickness (inches) ^A	Nominal Weight in lbs./100 Sq. Ft. ^B	Design Size (inches) ^C		Opening Size (inches) ^C		Strand Size (inches)		Overall Thickness (inches)	Open Area
			SWD	LWD	SWO	LWO	Width	Thickness		
½"-0.050	0.034	22	0.500	1.26	0.292	1.000	0.104	0.038	0.038	58%
½"-0.080	0.056	55	0.500	1.26	0.290	1.000	0.105	0.060	0.060	58%
¾"-0.050	0.034	14	0.923	2.10	0.679	1.812	0.122	0.038	0.038	74%
¾"-0.080 (Lt)	0.056	26	0.923	2.10	0.637	1.750	0.143	0.060	0.060	69%
¾"-0.080(HVY)	0.056	33	0.923	2.10	0.561	1.750	0.181	0.060	0.060	61%
¾"-0.125	0.089	53	0.923	2.10	0.549	1.750	0.187	0.094	0.094	59%
1½"-0.080	0.056	18	1.33	3.15	1.044	2.750	0.143	0.060	0.060	78%
1½"-0.125	0.089	36	1.33	3.15	0.968	2.750	0.181	0.094	0.094	73%

*A The minimum thickness is absolute, not subject to minus variation.

*B A variation in weight per square ft. of ±10 % is permissible, based on the weight of any sheet or bundle.

*C A tolerance of ±10 % is permitted in dimensions, center to center.

EXPANDED METAL GRATING

Expanded metal grating is heavy-duty expanded metal produced by slitting and stretching thick steel plate (thickness ≥ 3 mm). Compared with standard expanded metal, expanded metal grating has a larger opening and a thicker strand, delivering good anti-skid performance and high load capacity. So, it is perfectly suitable for applications requiring high load capacity or high walk safety requirements, such as industrial platforms, stair treads, walkways and trailers.

Our expanded metal grating products come in a variety of sturdy and durable materials including carbon steel, galvanized steel, stainless steel, etc., to ensure it can maintain its best anti-skid performance and load capacity even working under the harshest environments.

Features

- 3-dimensional structure offers good anti-skid performance.
- High open area displaces snow, mud, and dirt underfoot easily and helps to keep walkways clean and provide a firm foothold.
- High strength-to-weight ratio delivers great load capacity and ensures safe passage.
- Sturdy and durable, low maintenance costs.



Available Materials



Carbon Steel

It is one of the most cost-effective metal materials with good rigidity and great durability. It is often galvanized or powder coated to enhance its corrosion resistance. It is widely used in support structures.

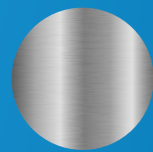

Galvanized Steel

It is a type of steel that has been galvanized to enhance its corrosion resistance and anti-aging performance. It is widely used in various industrial applications including walkway gratings, stair treads, greenhouse benches, etc.



Aluminum

It features easy to form, high strength-to-weight ratio, great corrosion resistance and fire resistance. The surface is usually anodized or PVDF coated. It is an ideal material for architectural decoration applications.

Hole Pattern

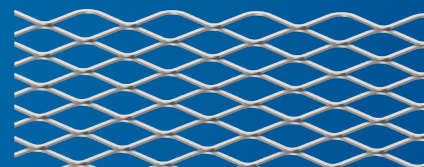

Diamond

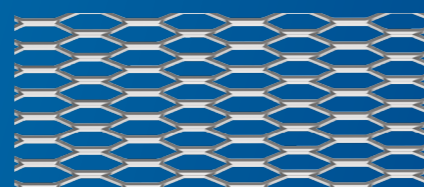

Hexagonal

Specification

Specifications of Carbon Steel Expanded Metal Grating

Style	Nominal Weight in lbs./100 Sq. Ft. ^B	Design Size (inches) ^C		Opening Size (inches) ^C		Strand Size (inches)		Overall Thickness (inches)	Open Area
		SWD	LWD	SWO	LWO	Width	Thickness		
2.0 lb.	2.00	1.33	5.33	1.000	3.60	0.235	0.135	0.460	77%
3.0 lb.	3.00	1.33	5.33	0.940	3.44	0.264	0.183	0.540	60%
3.14 lb	3.14	2.00	6.00	1.625	4.88	0.312	0.250	0.656	69%
4.0 lb	4.00	1.33	5.33	0.940	3.44	0.300	0.215	0.618	55%
4.27 lb	4.27	1.41	4.00	1.000	2.88	0.300	0.250	0.625	58%
5.0 lb	5.00	1.33	5.33	0.813	3.38	0.331	0.250	0.655	50%
6.25 lb	6.25	1.41	5.33	0.813	3.38	0.350	0.312	0.715	50%
7.0 lb	7.00	1.41	5.33	0.813	3.38	0.391	0.318	0.740	45%

*A A variation in weight per square ft. of $\pm 5\%$ is permissible, based on the weight of any sheet or bundle.

*B A tolerance of $\pm 5\%$ is permitted in dimensions, center to center.

Specifications of Stainless Steel Expanded Metal Grating

Style	Nominal Weight in lbs./100 Sq. Ft. ^B	Design Size (inches) ^C		Opening Size (inches) ^C		Strand Size (inches)		Overall Thickness (inches)	Open Area
		SWD	LWD	SWO	LWO	Width	Thickness		
3.3 lb.	3.32	2.00	6.0	1.625	4.88	0.312	0.250	0.656	69%
4.5 lb.	4.25	1.41	4.0	1.000	2.88	0.300	0.250	0.625	58%

*A A variation in weight per square ft. of $\pm 5\%$ is permissible, based on the weight of any sheet or bundle.

*B A tolerance of $\pm 5\%$ is permitted in dimensions, center to center.

Specifications of Aluminum Expanded Metal Grating

Style	Nominal Weight in lbs./100 Sq. Ft. ^B	Design Size (inches) ^C		Opening Size (inches) ^C		Strand Size (inches)		Overall Thickness (inches)	Open Area
		SWD	LWD	SWO	LWO	Width	Thickness		
2.0 lb.	2.0	1.33	5.33	0.940	3.44	0.387	0.250	0.730	48%

*A A variation in weight per square ft. of $\pm 5\%$ is permissible, based on the weight of any sheet or bundle.

*B A tolerance of $\pm 5\%$ is permitted in dimensions, center to center.

Carbon Steel - Concentrated Load Deflection Tables for a Fixed-Fixed Span

Style (lbs. per sq. ft)		24-Inch Span	36-Inch Span
3.0#	Concentrated Load Capacity (lb./ft.)	274	126
	Deflection Under Allowed Concentrated Load (in.)	0.25	0.25
3.14#	Concentrated Load Capacity (lb./ft.)	340	117
	Deflection Under Allowed Concentrated Load (in.)	0.25	0.25
4.0#	Concentrated Load Capacity (lb./ft.)	468	201
	Deflection Under Allowed Concentrated Load (in.)	0.25	0.25
4.27#	Concentrated Load Capacity (lb./ft.)	419	196
	Deflection Under Allowed Concentrated Load (in.)	0.25	0.25

* The test specimens on which this table is measured were welded at alternate strands to an angle fixture. Testing shows that if the ends are not so welded, the capacity of the grating is drastically reduced.

Aluminum - Concentrated Load Deflection Tables for a Fixed-Fixed Span

Style (lbs. per sq. ft)		24-Inch Span	36-Inch Span
2.0#	Concentrated Load Capacity (lb./ft.)	320	136
	Deflection Under Allowed Concentrated Load (in.)	0.25	0.25

* The test specimens on which this table is measured were welded at alternate strands to an angle fixture. Testing shows that if the ends are not so welded, the capacity of the grating is drastically reduced.

SMALL HOLE EXPANDED METAL

Small hole expanded metal is a small hole light-duty expanded metal produced by using precision punching and shearing machine through slitting and stretching. It is one of the preferred materials used in building protection and reinforcement design, filter element support and small-scale electric appliance heat dissipation applications.

With 37 years of experience in expanded metal manufacturing, we can not only supply common types of small hole expanded metal products, but also meet all your expanded metal customization requirements easily.

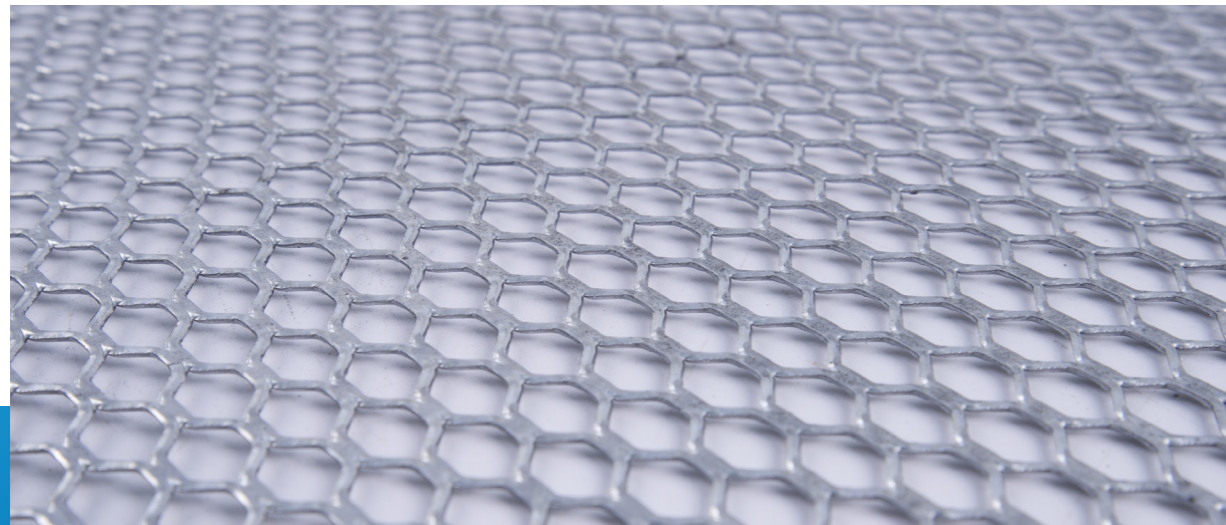

Features

- One-piece construction material, sturdy and durable, and edges are not easy to loose.
- Small hole effectively prevents flies, bees and other insects from entering.
- High temperature resistance and good heat dissipation capacity.
- Good sound absorption capacity.

Available Materials

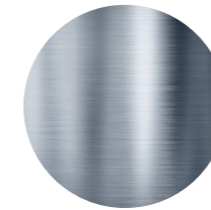

Carbon Steel

It is one of the most cost-effective metal materials with good rigidity and great durability. It is often galvanized or powder coated to enhance its corrosion resistance. It is widely used in support structures.

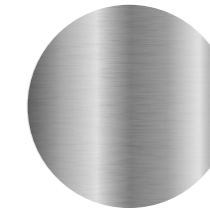

Galvanized Steel

It is a type of steel that has been galvanized to enhance its corrosion resistance and anti-aging performance. It is widely used in various industrial applications including walkway gratings, stair treads, greenhouse benches, etc.

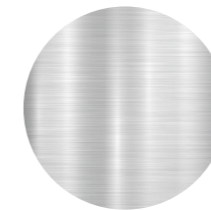

Stainless Steel

It has excellent corrosion resistant, impact resistant and fireproof characteristics. It has a bright, maintenance-free and easy to spray surface. It is widely used in various industrial and building decoration applications.

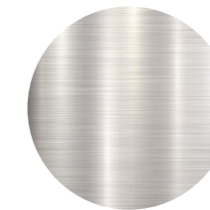

Aluminum

It features easy to form, high strength-to-weight ratio, great corrosion resistance and fire resistance. The surface is usually anodized or PVDF coated. It is an ideal material for architectural decoration applications.

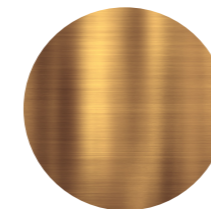

Copper

It is a safe and recyclable metal material with good softness, ductility, thermal and electrical conductivity. It is widely used in electrical appliances heat dissipation, Faraday cage, architectural decoration applications, etc.

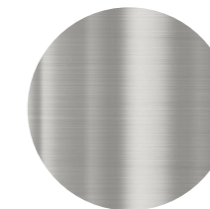

Nickel

It is a silvery-white metal material with good magnetic properties, high ductility and electrical conductivity. In addition, it is not easily oxidized in air and is often used to make special steels and other alloys, catalysts, etc.

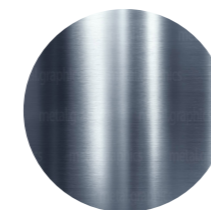

Titanium

It has a low density and the highest strength-to-weight ratio among all metallic elements. Besides, it has the highest corrosion resistance in seawater and chlorine. It is non-magnetic and has low thermal and electrical properties.

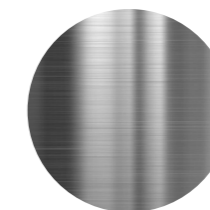

Other Alloy

We also supply other alloy materials with higher rigidity, corrosion resistance, and other special properties for expanded metal production to suit to harsh working conditions and meet your special project requirements.

Hole Pattern

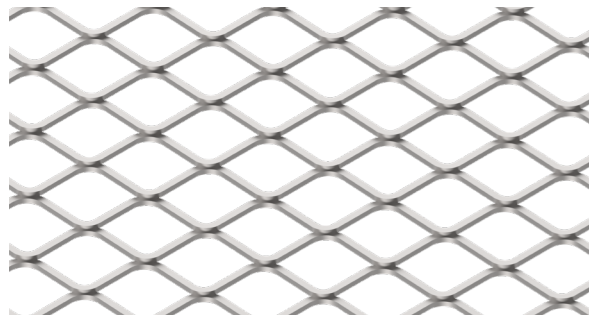

Diamond

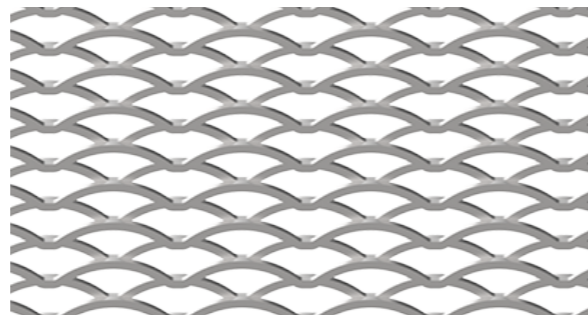

Fan-shaped

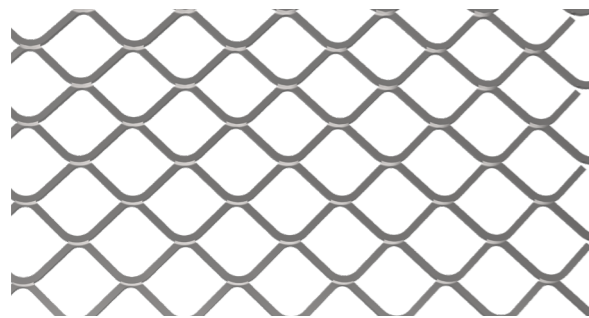

Square

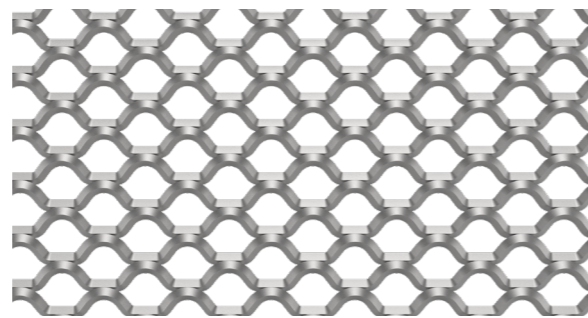

Round

Specification

Small Diamond Designs-Carbon Steel-Standard

Style	Nominal Weight in lbs./100 Sq. Ft. ^A	Design Size (inches) ^B		Opening Size (inches) ^B		Strand Size (inches)		Overall Thickness (inches)	Open Area
		SWD	LWD	SWO	LWO	Width	Thickness		
3/32"-#24	56	0.140	0.240	0.084	0.135	0.040	0.024	0.083	43%
1/8"-#24	52	0.150	0.300	0.094	0.155	0.040	0.024	0.083	47%
3/16"-#24	26	0.190	0.500	0.145	0.375	0.034	0.018	0.069	64%
3/16"-#24	49	0.200	0.500	0.136	0.325	0.050	0.024	0.101	50%
3/16"-#24	72	0.210	0.500	0.131	0.308	0.060	0.031	0.122	43%
1/4"-#24	51	0.250	0.670	0.180	0.473	0.050	0.031	0.104	60%

*A A variation in weight per square ft. of $\pm 10\%$ is permissible, based on the weight of any sheet or bundle.

*B A tolerance of $\pm 10\%$ is permitted in dimensions, center to center.

DECORATIVE EXPANDED METAL



Decorative expanded metal is a new building decoration material generally made of aluminum or lightweight steel plate after slitting and stretching. It comes in a variety of powder coated, anodized and PVDF finishes, and features lightweight, high load capacity, good corrosion resistance and anti-aging. It not only brings unique charm to buildings, but also offers best practical functions. So, it is an eco-friendly building decoration material popular among architectural designers.

We offer decorative expanded metal products in a variety of materials, colors and hole patterns for you to choose from. Just contact us, our professional designer will work with you and find the right expanded metal products and make out best custom solutions together.

Features

- Provide innovative, flexible building decoration materials for designers and architects.
- Uniform openings allow free passage of light and air.
- A perfect combination of functionality and aesthetics. It not only creates distinctive exterior appearance for buildings, but also achieves exterior wall protection, sunshade, partition and other practical functions.
- A variety of materials, colors, patterns, finishes and textures for you to choose from.

Powder Coated

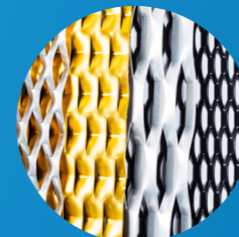

Anodized

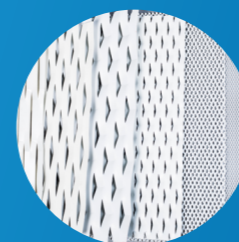

PVDF Coated

Popular Hole Patterns

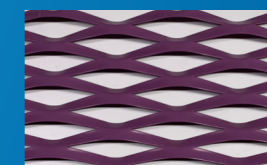

Diamond

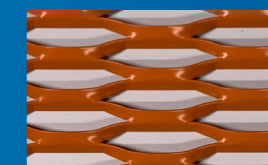

Hexagonal

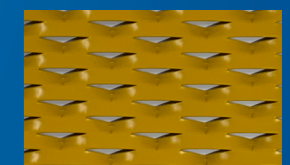

Triangle



Special-shaped



Elongated hexagonal



Gothic



APPLICATION

We strive to improve our technology and equipment to make our expanded metal get an ever-increasing application. We will continue to explore and develop new expanded metal application fields and make out custom expanded metal solutions with our extensive experience and strong R&D capacity.



Security & Protection

It is mainly used to provide security protection for key infrastructure and mechanical equipment.



Decoration

A popular modern building decorative material combines aesthetics and functions.

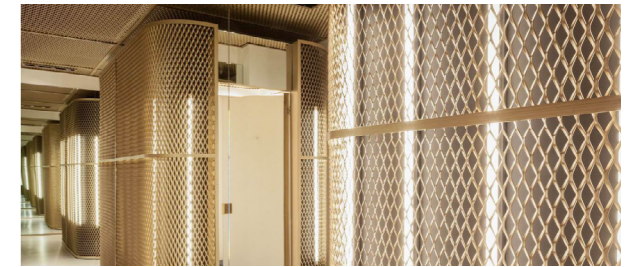

Construction

It is mainly used to enhance the entire building structure and extends the service life of buildings.

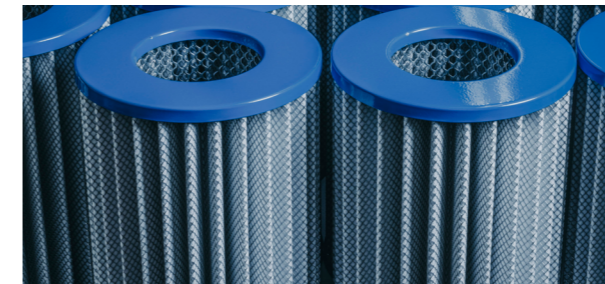

Filtration

It can act as the filter element support layer and function as the main filter media to achieve efficient filtration.



Automobile

It is mainly used as automobile inlet grilles, pickup headache racks, speaker grills, etc.



Engineering

Rigid structure, excellent load capacity and anti-skid performance.



More

It is often used as grill trays, trailer tool cabinet, skylight guards, shelf decking, chimney covers, etc.

SECURITY & PROTECTION



Security Fence

Unlike other security fence products on the market (woven mesh fence and welded fence), expanded metal security fence is made of one-piece solid steel plate by slitting and stretching. This special construction makes it so strong that intruders cannot cut it with common tools. Besides, it is hard to climb, so it offers high security and is widely used in road protection, construction sites, border security and other applications requiring security protection to protect the safety of facilities and personnel inside the fence.

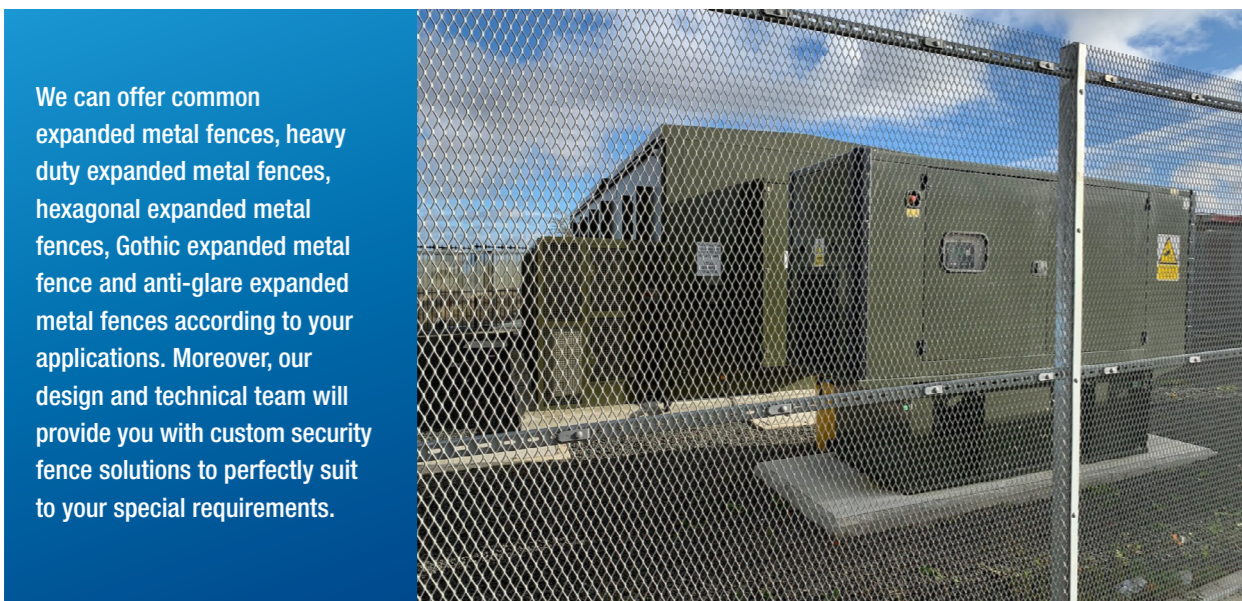

We can offer common expanded metal fences, heavy duty expanded metal fences, hexagonal expanded metal fences, Gothic expanded metal fence and anti-glare expanded metal fences according to your applications. Moreover, our design and technical team will provide you with custom security fence solutions to perfectly suit to your special requirements.

Features

- **High strength.** Made of one-piece solid steel plate by slitting and stretching, no weld joints, its special opening structure offers good rigidity and can withstand heavy impact.
- **Anti-cut.** It cannot be cut easily with common tools and can delay and even prevent intruders from entering.
- **Visibility.** Through the uniform opening, the outside scene can be seen clearly.
- **Anti-climb.** Its special opening structure makes the intruder cannot find a foothold, thus preventing the intruder from climbing and crossing over the fence.
- **Extraordinary durability.** Expanded metal security fence after galvanized and powder coated surface treatment will not corrode easily even under rainy, moisture and other bad weather, thus reducing maintenance and replacement costs.



Common Expanded Metal Fence

Common expanded metal fences are generally made of standard expanded metal after hot dip galvanized or PVC coated treatment. It has excellent corrosion resistance and anti-aging performance and is widely used as road protection fences, bridge protection fences, stair handrails, balcony fences, farm fences, etc.

Diamond Opening Structure

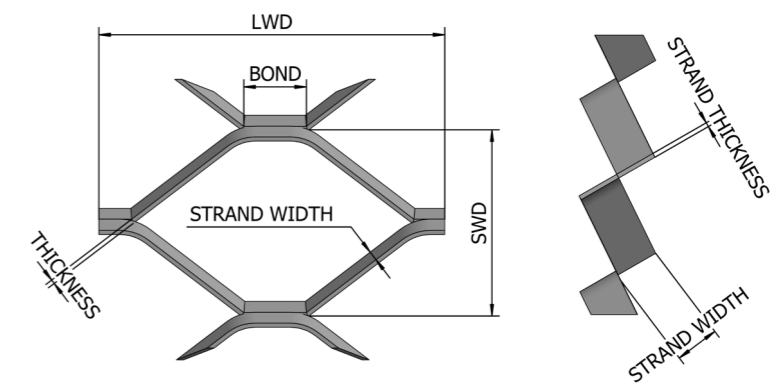

Specification

Material:	Carbon steel, stainless steel
Hole pattern:	diamond
Thickness:	3 mm – 5 mm
Opening size (SWD × LWD)	40 × 80 mm, 50 × 100 mm, 55 × 100 mm, 70 × 150 mm
Finish:	hot dip galvanized; PVC coated

Heavy Duty Expanded Metal Fence



Compared with common expanded metal fence, heavy duty expanded metal fence is made of a thick expanded metal, generally with a thickness of 8–10 mm. Therefore, it has higher strength and better anti-cut performance, it is a high security fence solution. It often works with barbed wire or bend the fence top to enhance its anti-climb performance and effectively delay and even prevent enemy invasion. It is widely used in airport, military protection, prisons, government agencies, public utilities and other places requiring higher security.

Diamond Opening Structure

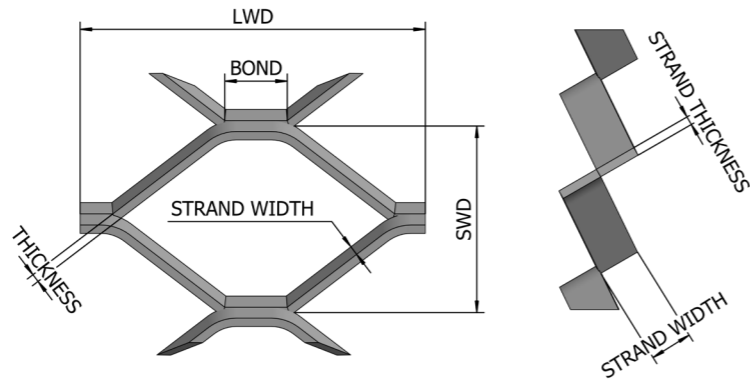

Specification

Material:	Carbon steel, stainless steel
Hole pattern:	diamond
Thickness:	8–10 mm
Finish:	hot dip galvanized.

Hexagonal Expanded Metal Fence

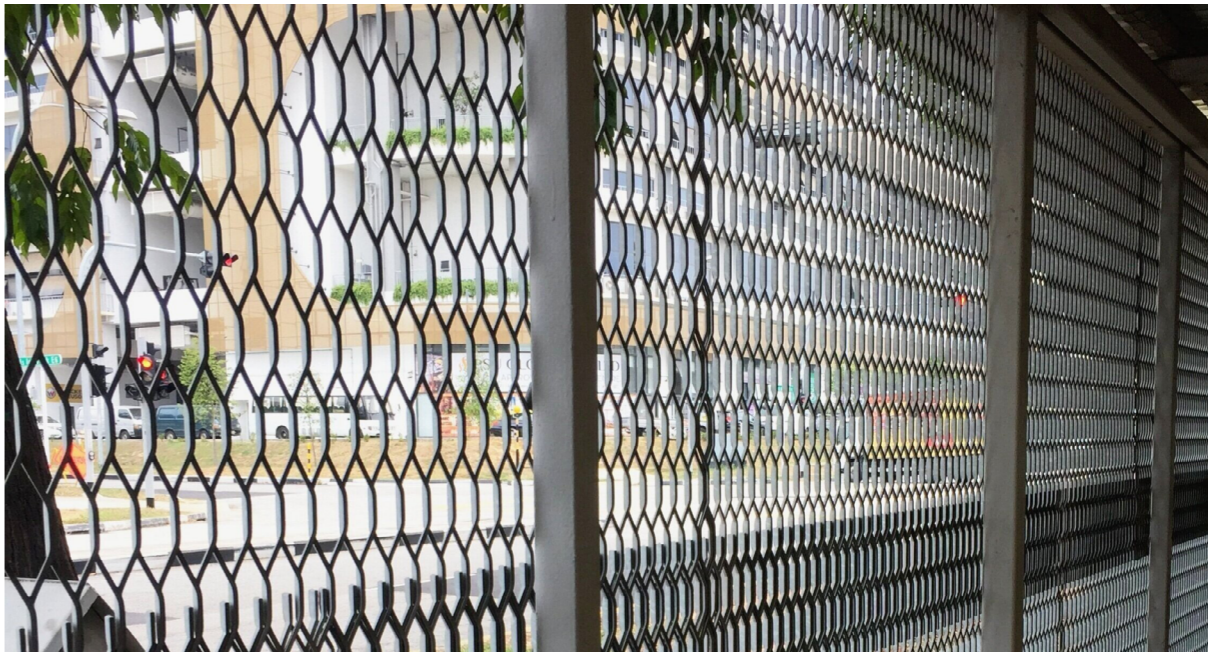

Hexagonal expanded metal fence has solid structure, high security and aesthetics. Its geometric construction delivers a greater open area, so it has better visibility and ventilation performance and is widely used as building fences, stair handrails, farm fences, etc.

Hexagonal Opening Structure

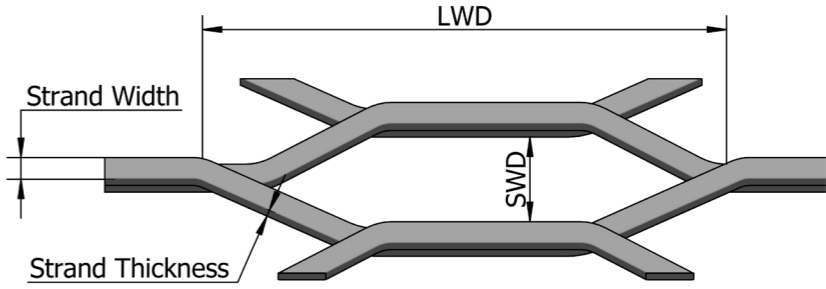

Specification

Material	Opening Size (mm)		Strand (mm)		Open Area	Weight (kg/m ²)
	LWD	SWD	Strand Width	Strand Thickness		
Carbon steel	45	13	5	3	24%	17.5
	45	18	4	3	55%	11

Gothic Expanded Metal

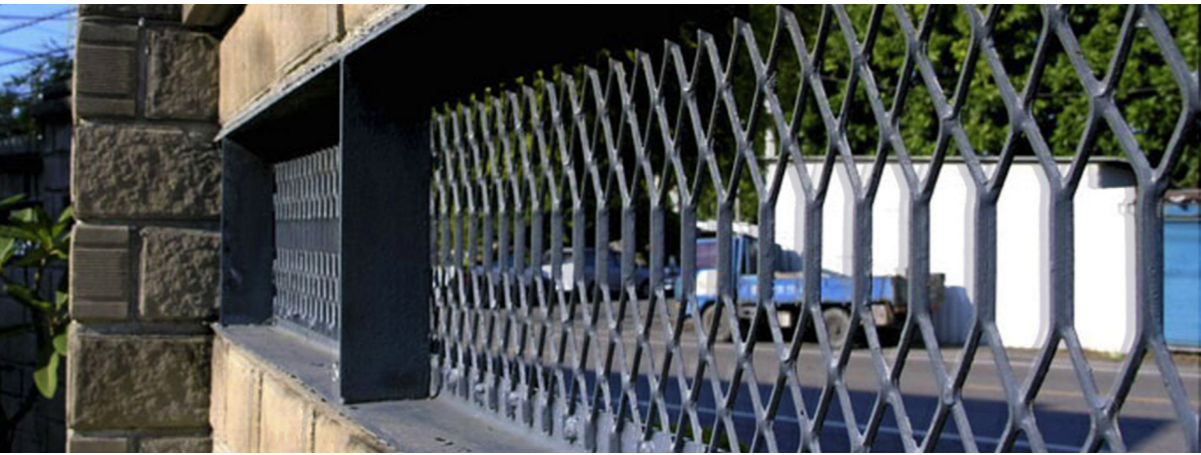

Gothic expanded metal fence is made of expanded metal with special-shaped openings and an attractive appearance. Its hot dip galvanized or powder coated surface makes it have excellent corrosion resistance and anti-aging performance, thereby enjoying a more durable lifespan. It is widely used in windows, gates, gardens, etc., and can provide both great security protection and amazing decoration effect.

Gothic Opening Structure

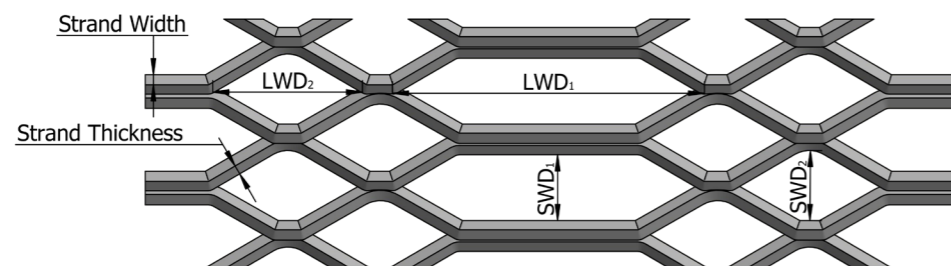

Specification

Material	Large Opening Size (mm)		Small Opening Size (mm)		Strand (mm)		Zinc Coating (g/m ²)
	SWD1	LWD1	SWD2	LWD2	Strand Width	Strand Thickness	
Hot dip galvanized steel	27	76	27	38	3.2	2.8	> 280
					2.3	3.2	
					2.4	3.2	
	25	80	25	40	3.2	2.8	
					2.3	3.2	
					2.4	3.2	

We can develop new moulds and provide Gothic expanded metal fence in other sizes.

Anti-Glare Expanded Metal Fence



Anti-glare expanded metal fence is made of expanded metal wrapped with metal frame. It is generally installed along two-way road isolation strips to ensure the continuity of the anti-glare facilities and its horizontal visibility and achieve anti-glare and isolation purposes, thereby safeguarding the driving safety of drivers.

Gothic Opening Structure

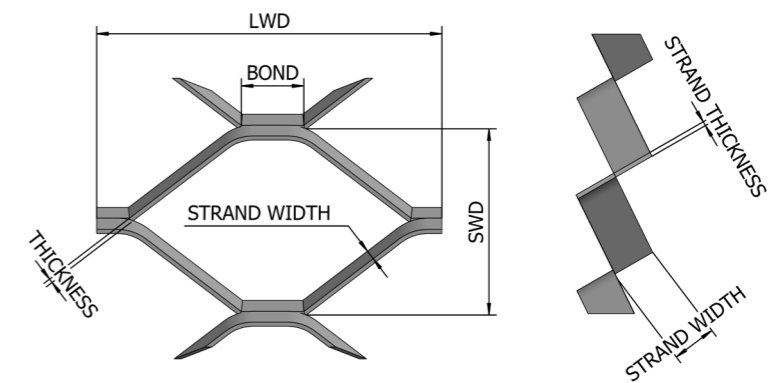

Specification

Material:	Carbon steel, stainless steel
Hole pattern:	diamond
Thickness:	2 mm – 3 mm
Opening size (SWD × LWD)	30 × 75 mm
Strand width:	8 mm
Color:	green, blue
Finish:	galvanized, powder coated

Machine Guards

Safety is always a great concern in production, especially in the manufacturing industry. The equipment operation not only brings us economic benefits, but also put operators in a dangerous workplace. So, machine protection becomes very important.

Our expanded metal machine guards are mainly used in machine perimeter protection and partial protection. The guard surface is generally electrostatic powder coated with alarming color, such as yellow and orange, aiming to reduce the occurrence of production accidents and ensure the personal safety of operators. All our expanded metal machine guards comply with OSHA (Occupational Safety and Health Administration) 1910.212 general requirements.

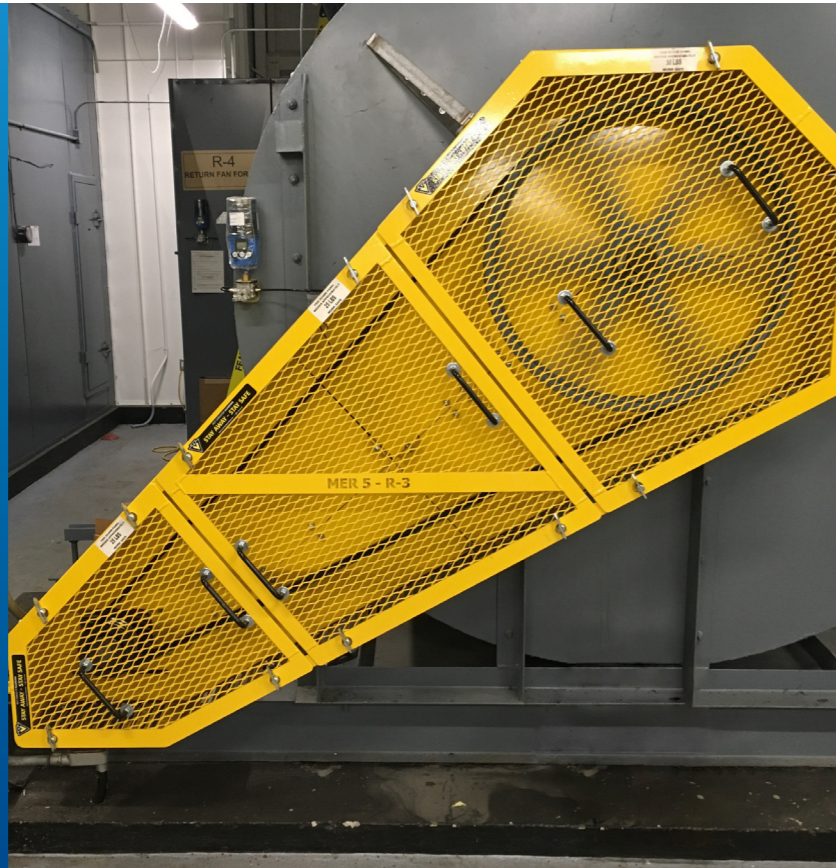

Features

- **Economical & eco-friendly.** Made of solid steel plate after slitting and stretching, no material is wasted during the production.
- **Visibility.** Uniform openings allow the free passage of air and light and can observe the equipment operation directly without removing the machine guards.
- **Safety.** Rigid structure and different opening size can effectively prevent fingers or body part from coming into contact with hazardous parts and protect the personal safety of operators.
- **Durability.** Powder coated surface offers enhanced corrosion resistance.
- **Formability.** It can be cut, bent and welded to meet the safety protection requirements of different machines.

Machine Partial Guards

It is mostly used to protect flywheels, fan blades, belt pulleys, gears, connecting rods and other machine components that transmit energy to protect workers operating or working around the machinery. Besides, it also prevents clippings or other sharp objects from entering the machine, thus reducing the equipment abrasion and protecting the key assets of the enterprise.

Machine partial guards are generally made of flattened expanded metal. It features good rigidity, stable structure and its flat, smooth surface not only provides great safety protection, but also facilitates the operator accessing to the machine.



Material	Carbon steel, stainless steel
Hole pattern	diamond
Thickness	2 mm – 3 mm
Opening size (mm)	5 × 23, 8 × 24, 10 × 32
Thickness	2 mm – 4 mm
Finish	electrostatic powder coated

Machine Perimeter Guards

It is generally installed along the machines are prone to causing injuries, such as cutting machines, milling machines, forming rollers and calenders, to protect workers from chippings, flying chips or metal sparks generated during the machine operating. It usually consists of multiple pieces of expanded metal with frames, which is strong and easy to install and maintain.

Material	Carbon steel, stainless steel
Hole pattern	diamond
Opening size (mm)	30 × 60, 35 × 75, 40 × 80, 50 × 100
Thickness	2 mm – 4 mm
Finish	electrostatic powder coated

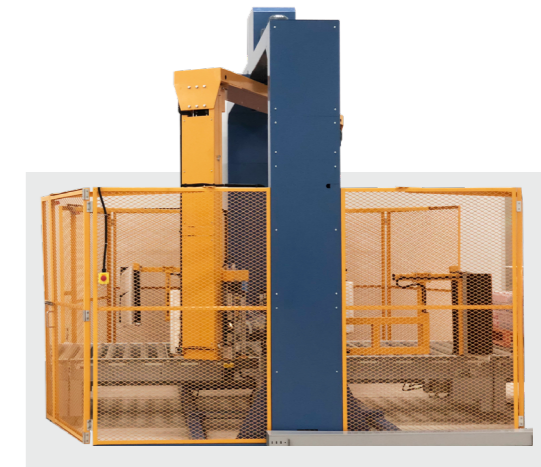

Outdoor Machine Cages

Expanded metal not only plays an important role in machine guarding, but also is widely used in various outdoor equipment protection applications, such as outdoor air condensing unit protection cages, outdoor return passage machine cages and construction sit important item protection cages.

Our expanded metal outdoor machine cages feature sturdy structure, good anti-cut performance and can effectively prevent vandals from damaging and attacking the important parts of outdoor equipment. In addition, the machine cage after powder coated treatment can resist the erosion of rain, hail and other bad weathers, and enjoy a longer service life.



Material	Opening Size (mm)		Strand (mm)		Open Area
	SWD	LWD	Strand Thickness	Strand Width	
Carbon steel	22.58	50.8	3	3.12	72%
stainless steel	40.64	85.73	3	3.18	84%

CONSTRUCTION



As for high rise buildings, civil building, commercial buildings and other important buildings, the overall stability and security must be taken into consideration during construction. As a cost-effective building protection material, expanded metal has been widely used in building walls, roofs, brickwork, etc., to enhance its overall structure, extend the service life of buildings and protect the life security of human beings.

DVA Mesh

DVA (Diminished Vision Aluminum) mesh, also known as one way vision mesh, is made of aluminum sheet that is slit and stretched with thousands of tiny holes. These holes are produced at a light downward angle, this unique design allows air and light into the room while keeping rain out. In addition, it also protects your privacy well and eliminates insolent peep. As a result, DVA mesh is a great choice for homeowners requiring higher window and door security, ventilation and visibility.

We can supply both popular 0.5 mm light duty DVA mesh and 2.0 mm heavy duty DVA mesh. Besides, we can develop new moulds to produce custom DVA mesh for you and meet your specific window and door security protection requirements.

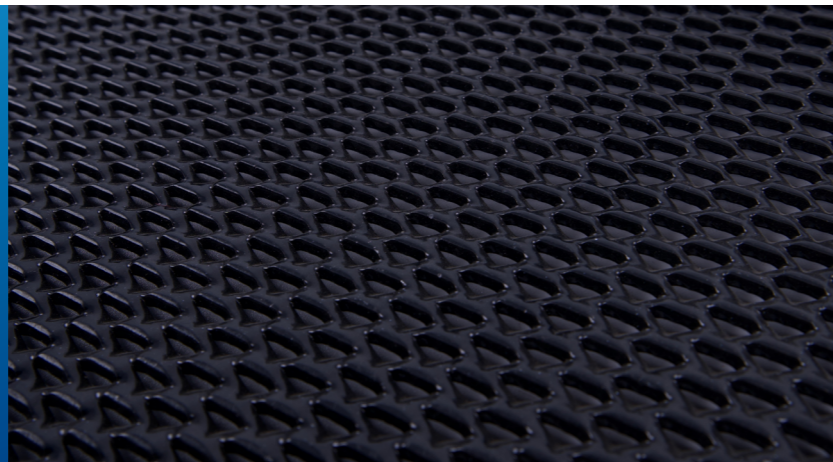

Features

- **Ventilation and rainproof.** Unique opening structure allows the free passage of air and light while effectively preventing up to 99.9% of rain water from entering and avoiding rain water wetting your indoor items.
- **Privacy protection.** One-way vision design allows you to look out the door from the inside without exposing your home to anyone outside, thus creating a great privacy space.
- **High security.** One-piece aluminum sheet construction delivers great anti-cut and anti-impact performance and has higher security than traditional woven mesh window screen.
- **Attractive appearance.** Its special opening design not only gives good vision decoration effect, but also supplies a preferred material for modern building window and door security protection.
- **Economical and durable.** Akzo Nobel polyurethane powder coated surface offers excellent corrosion resistance, anti-aging performance and enjoys a longer service life.

Category

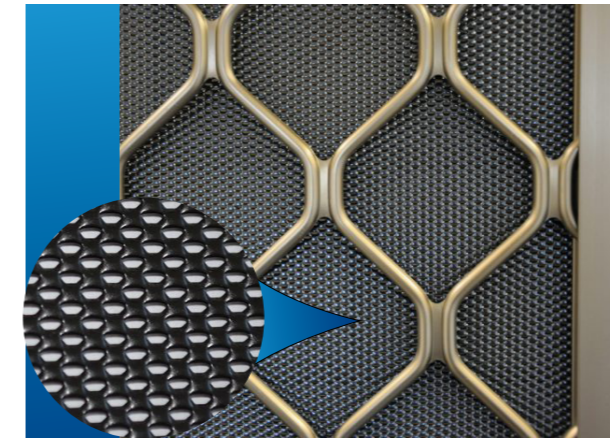

0.5 mm light duty DVA mesh

It is mainly used as window screen to prevent insects from entering the room. It often works with 7 mm diamond grille support.

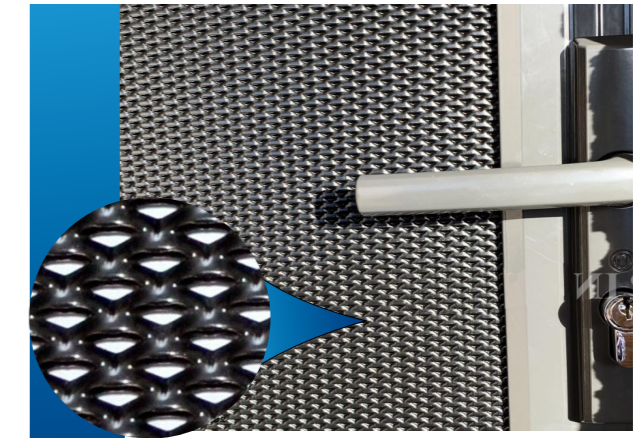

2 mm heavy duty mesh

Heavy duty DVA mesh is a kind of reinforced light duty DVA mesh with a rigid structure and good impact resistance. It can be used separately to serve as security doors and window guards.

Specification

Material	DVA Mesh Type	Strand mm		Opening Size (mm)		Panel Size (mm)
		Strand Thickness	Strand Width	SWD	LWD	Width × Length
Aluminum plate	Light duty DVA mesh	0.5	1.2	3	6.25	750 × 2000
	Heavy duty DVA mesh	2	2.5	5.7	8	750 × 2000

Surface treatment: Akzo Nobel polyurethane powder coated or mill finish.

Gallery



Heavy duty DVA mesh security door

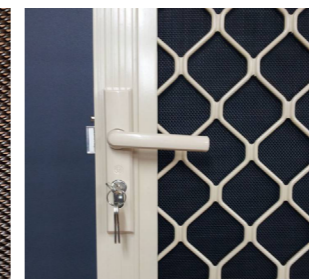

Light duty DVA mesh security door



DVA mesh window screen



DVA mesh sliding door

Expanded Metal Lath

Expanded metal lath is often used as the base of wall plastering during construction to reinforce the building walls. Raised mesh surface enhances the adhesion of stucco and can effectively avoid wall cracking arising from concrete or plaster constriction, thus improving the quality of buildings. It is widely applied on concrete, brick, wood, plaster and other all surfaces.

Our expanded metal lath is made of high quality galvanized steel or stainless steel materials with excellent corrosion resistance. In addition, all our materials comply with ASTM A653 and ASTM C847 standard requirements.

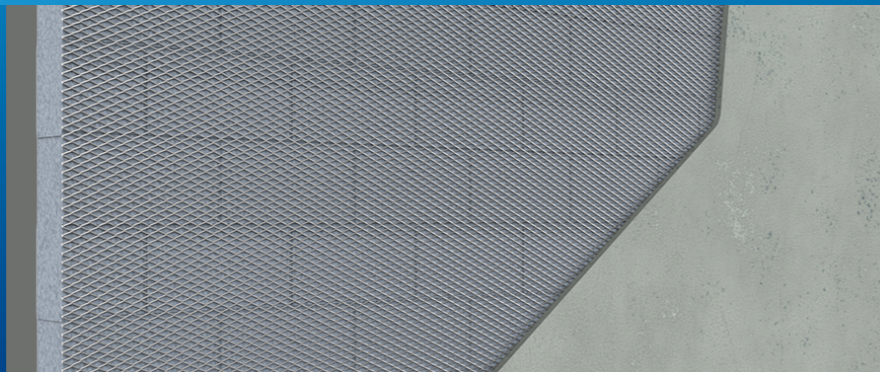

For Different Wall Part Reinforcement

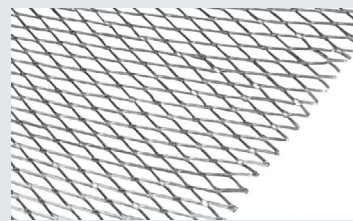

Flat diamond mesh lath

Generally made of raised expanded metal, it is mainly used as plaster base on building walls, ceilings and other large area places requiring reinforcement to prevent wall cracking and offer great impact resistance.

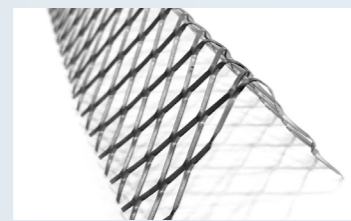

Corner mesh

Expanded metal is bent to an angle that suits to the wall corner. It is typically used in corners where walls meet walls or ceilings for reinforcement to prevent wall cracking.

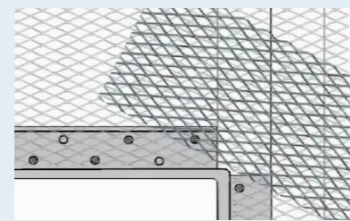

Strip lath

It is made of flattened expanded metal that has been cut into strips. It is generally installed at the window and door corners or areas that are prone to cracking to enhance its capacity against the concentration of stress and cracking.

Specification

Material	Thickness (mm)	Opening Size (mm)		Weight (kg/m ²)
		SWD	LWD	
G60 galvanized steel	0.50	10	20	1.11
	0.70	10	20	1.61
	0.40	10	20	0.90
	0.90	9	29	2.62
	0.40	9	29	1.15
	0.50	9	29	1.92

Finish: hot dip galvanized, zinc coating is greater than 183 g/m² and complies with and exceeds ASTM A653 standard requirements.

Gallery



Brick wall reinforcement

Concrete wall reinforcement

Ceiling reinforcement

Brick Reinforcement Mesh

Brick reinforcement expanded metal mesh is mainly used to reinforce the brickwork of building door and window openings, aiming to reduce the damage caused by vibration and temperature changes and avoid cracking around door and window openings, thus enhancing the overall structure of the wall.

Our brick reinforcement expanded metal mesh is made of high quality galvanized steel or stainless steel sheet that has been slit and stretched. It is supplied in coils to facilitate workers using during construction.



Features

- Raised mesh surface provides good adhesion and high tensile stress resistance for stucco and plaster, thereby stabilizing the structure between bricks.
- Effectively reduce the risk of cracking around brickwork of high stress areas, such as windows or doors.
- Hot dip galvanized surface provides excellent corrosion resistance and a long lifespan.
- Packed in coils, easy to transport and facilitate workers using during construction.

Category

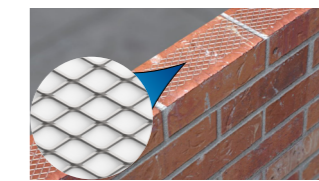

Diamond brick reinforcement mesh

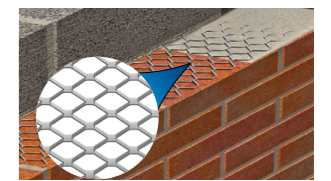

Hexagonal brick reinforcement mesh

Specification

Material	Thickness (mm)	Hole Pattern	Opening Size (SWD × LWD/mm)	Coil Width (mm)	Length (m)
Galvanized steel, stainless steel	0.3–0.5	Diamond, hexagonal	15 × 25	65	20
				115	20
				178	20
				225	20
				305	20

How to Install?

- When laying the brick reinforcement mesh, construction workers need to wear protective gloves to avoid injuries caused by sharp edges of the mesh.
- The mesh should provide a minimum 25 mm gap to external faces.
- If joining two lengths together, a minimum 75 mm overlap should be included.
- For most brick reinforcement, the mesh can be laid every three courses.

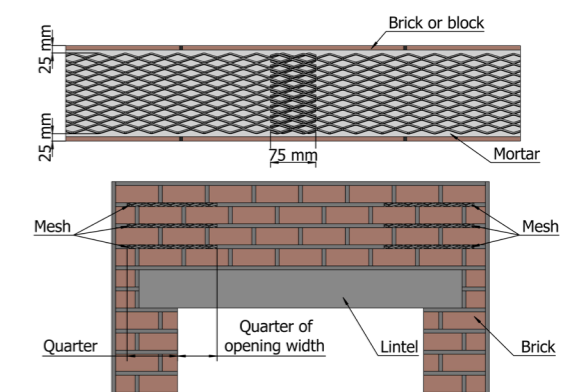

Expanded Metal Gutter Guards

Expanded metal gutter guards are a kind of gutter protection device. It is generally installed on roofs to intercept fallen leaves, branches and debris to ensure the water can be drained out timely and prevent roof damage caused by gutter clogging. Our standard expanded metal and flattened expanded metal gutter guards provide a cost-effective solution for gutter protection.

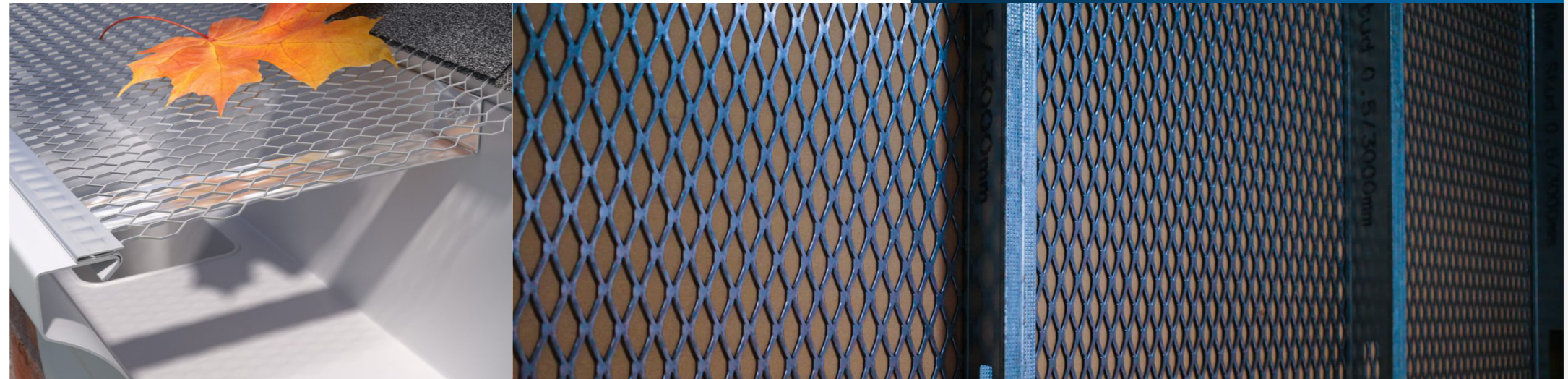

Specifications of Expanded Metal Gutter Guards

Material	Strand Thickness (mm)	Strand Width (mm)	SWD (mm)	LWD (mm)	Panel Width (mm)	Panel Length (mm)
Aluminum sheet	0.5	0.75	4.4	6.25	1000	5000

Finish: Akzo Nobel powdered coated.

Expanded Metal Bolt Boxes

Expanded metal bolt boxes are used in concrete structures to secure bolts. When the bolt box is accurately positioned, fill the cavity of the bolt box with cement slurry to secure bolts to the foundation and enhance the stability of steel columns.

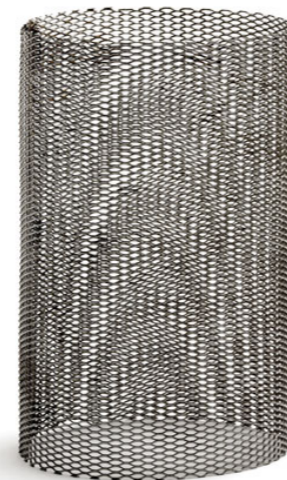

Specifications of Expanded Metal Bolt Boxes

Strand Thickness (mm)	Strand Width (mm)	Opening Size (SWD x LWD, mm)	Open Area	Diameter (mm)	Length (mm)
0.60	0.79	3.50 x 5.48	55%	75	150-300
0.60	0.79	3.50 x 5.48	55%	100	375-600

Expanded Metal Drywall Security Mesh

Expanded metal is secured inside the wood or plaster wall to prevent or delay intruders from entering the building. It is suitable for installing in correctional facilities, government offices, computer rooms, airport security, military facilities or any building facility that requires strict protection.

Specifications of Expanded Metal Drywall Security Mesh

Strand Thickness (mm)	Strand Width (mm)	Opening Size (SWD x LWD, mm)	Open Area	Maximum Panel Size (mm)
2.69	4.6	22.58 x 50.80	61%	1220 x 2440

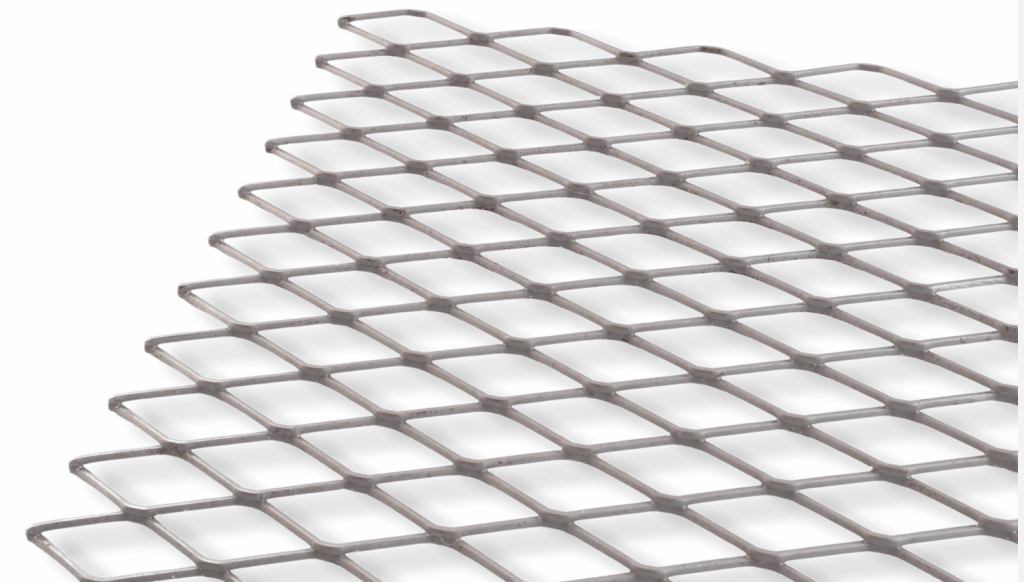

ENGINEERING



Expanded metal is a one-piece mesh material made of solid steel plate after slitting and stretching. It is sturdy and durable and offers excellent load capacity and anti-skid performance. As a result, it can create safe working conditions for pedestrians and equipment. It is widely used in walkways, stair treads, greenhouse benches, trailer ramps, etc. We can provide custom expanded metal solutions for your specific engineering projects to meet your application demand.

Walkway

Expanded metal walkway offers high load capacity and excellent anti-skid performance. So, it is widely used in various industries to provide a safe passage for construction, transportation, maintenance activities, for example, overpass walkway, oil and gas platform, offshore platform, solar panel construction, roof platform systems, etc.



We can supply aluminum, carbon steel, stainless steel and other expanded metal walkways. They are generally have galvanized or powdered coated treated to enhance its corrosion resistance and extend its service life.

Features

- **Excellent anti-skid performance.** Raised mesh surface enhances the friction between underfoot and walkway contact area to prevent pedestrians from slipping and ensure walking security.
- **High load capacity.** Made of 3 mm – 8 mm thick steel plates that are thicker than standard expanded metal, no welding joint. Besides, large strand width and opening size also deliver higher load capacity.
- **Corrosion resistance.** Galvanized or powder coated surface makes it have excellent resistant to acids and bases.
- **Easy maintenance.** Opening design makes the dirt, rain and snow fall off smoothly, reduce the frequency of cleaning and maintenance.

Category

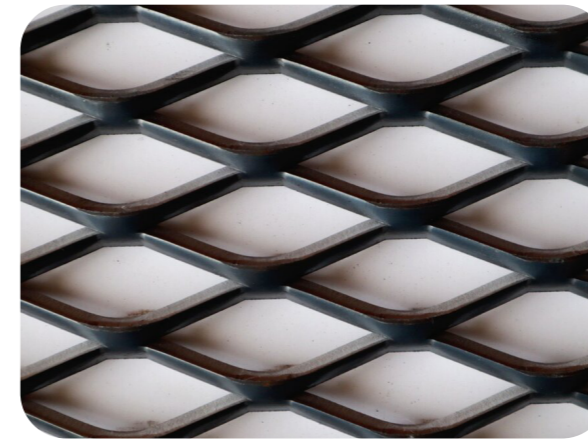

Diamond

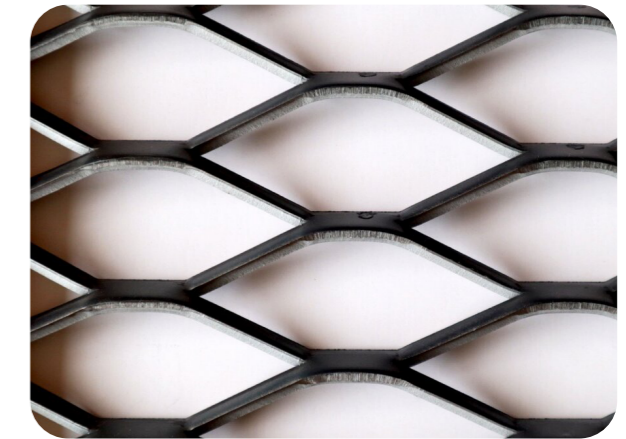

Hexagonal

Specification

Material	Opening Size (mm)		Strand (mm)		Weight (kg/m ²)
	SWD	LWD	Thickness	Strand Width	
Carbon steel, galvanized steel, aluminum	30	75	3.0	7.0	10.70
	34	76	4.0	5.0	8.80
	30	75	5.0	7.5	23.00
	42	135	5.0	8.0	14.05
	30	75	5.0	10.5	27.00
	45	135	5.0	11.0	19.00

Gallery

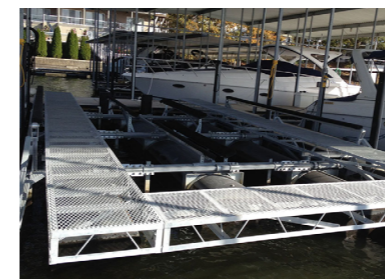

Surface platform walkway



Overhead pipe walkway



Industrial platform walkway

Stair Treads

Expanded metal stair treads have excellent anti-skid performance and high load capacity, and are very suitable for moving stairs, stationary stairs and spiral stairs in project construction. We can provide expanded metal stair treads perfect match up with your application environments to provide safety protection for your construction workers.

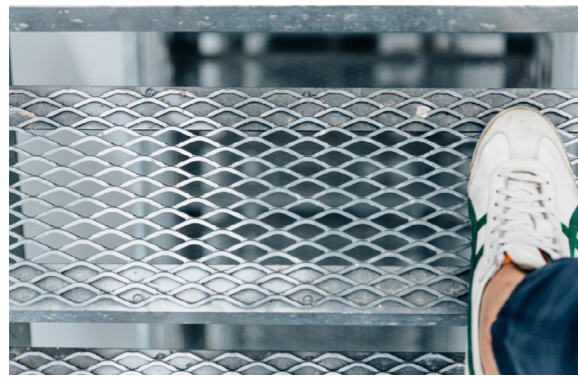

- Excellent anti-skid performance makes pedestrians free from falling risks arising from slipping.
- Rigid structure offers high load capacity and strong, stable support.
- Diamond openings help snow, water, grease and fluid to drain out.
- Unique surface structure can effectively avoid dazzling feeling when people looking down from a high place.

Specification

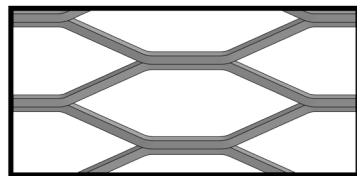

2.0 lb, 3.0 lb, 4.0 lb, 5.0 lb, 6.25 lb, 7.0 lb

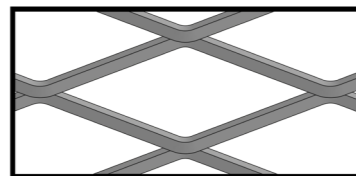

3.14 lb

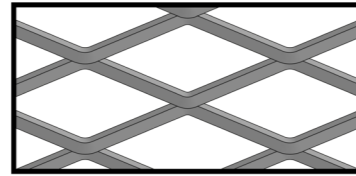

4.27 lb

Carbon Steel Expanded Metal Stair Treads

Material	Weight (lbs./ft ²)	Opening Size (Inch)		Strand (Inch)		Open Area
		SWD	LWD	Width	Thickness	
Carbon steel	2.00	1.33	5.33	0.24	0.14	77%
	3.00	1.33	5.33	0.26	0.18	60%
	3.14	2.00	6.00	0.31	0.25	69%
	4.00	1.33	5.33	0.30	0.22	55%
	4.27	1.41	4.00	0.30	0.25	58%
	5.00	1.33	5.33	0.33	0.25	50%
	6.25	1.41	5.33	0.35	0.31	50%
7.00	1.41	5.33	0.39	0.32	45%	

Stainless Steel Expanded Metal Stair Treads

Material	Weight (lbs./ft ²)	Opening Size (Inch)		Strand (Inch)		Open Area
		SWD	LWD	Width	Thickness	
Stainless steel	3.32	2.00	6.00	0.31	0.25	69%
	4.25	1.41	4.00	0.30	0.25	58%

Aluminum Expanded Metal Stair Treads

Material	Weight (lbs./ft ²)	Opening Size (Inch)		Strand (Inch)		Open Area
		SWD	LWD	Width	Thickness	
Aluminum	2.00	1.33	5.33	0.39	0.25	48%

Load Capacity Diagram

The load capacity of expanded metal stair treads is mainly reflected in 2 aspects of transverse uniform load and concentrated load. Our expanded metal stair treads comply with EMMA 557-15 standard requirements.

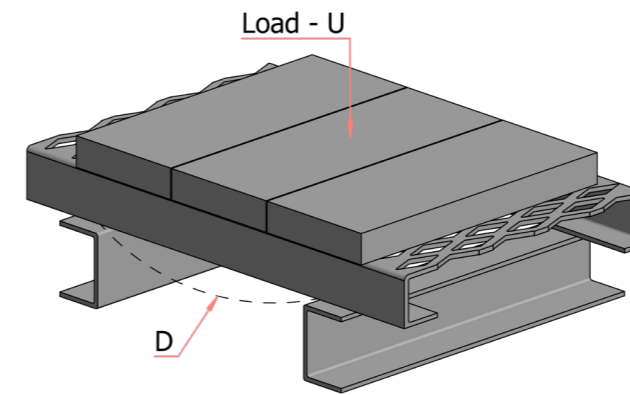

Uniform load and deflection diagram

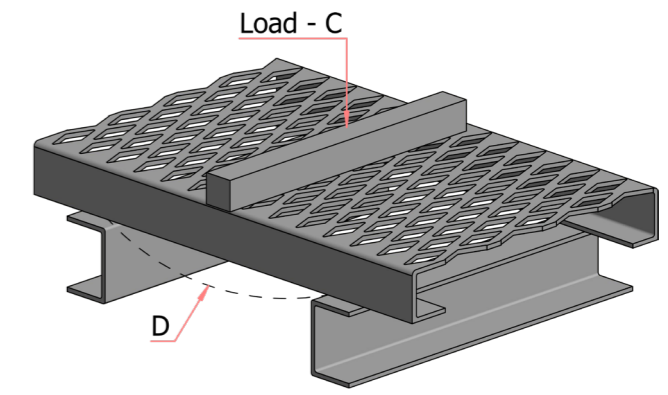

Concentrated load and deflection diagram

Carbon Steel Expanded Metal Stair Tread Concentrated Load & Deflection Table

Style (lbs./ft ²)	Concentrated Load C (lb./ft.) & Deflection D (in.)	24-Inch Span	36-Inch Span
3.0#	C	274	126
	D	0.25	0.25
3.14#	C	340	117
	D	0.25	0.25
4.0#	C	468	201
	D	0.25	0.25
4.27#	C	419	196
	D	0.25	0.25

Aluminum Expanded Metal Stair Tread Concentrated Load & Deflection Table

Style (lbs./ft ²)	Concentrated Load C (lb./ft.) & Deflection D (in.)	24-Inch Span	36-Inch Span
2.0#	C	320	136
	D	0.25	0.25

Notes:

- The allowable tolerance for weight per square foot is $\pm 5\%$.
- Both ends of the tested expanded metal stair tread have been welded to a fixed metal frame.

Gallery

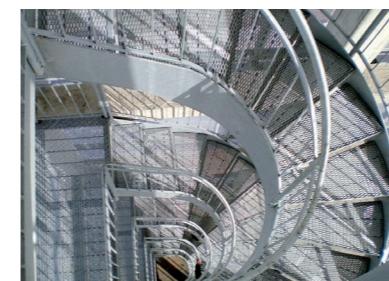

Spiral stairs



Stationary stairs

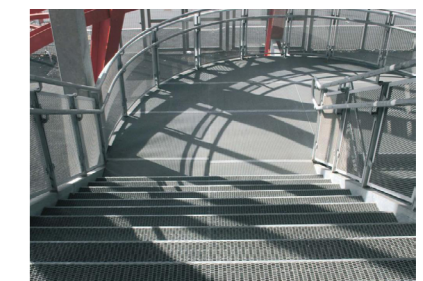

Industrial platform stairs



Greenhouse Benches

In the greenhouse planting industry, expanded metal greenhouse benches are very popular and provide a strong, solid support for potted plants. Expanded metal for greenhouse benches is generally flattened expanded metal to provide a flat surface and prevent potted plants from falling off. In addition, uniform opening allows the free passage of air and sunlight, creating a sound growing environment for plants in the greenhouse.



- Uniform opening allows the free passage of air and sunlight, creating a superior growing environment for plants.
- Unique one-piece construction makes it have higher load capacity than ordinary welded mesh.
- Large open areas contribute to draining out excessive water after irrigation, keeping the greenhouse bench clean and dry.
- Hot dip galvanized surface offers excellent corrosion resistance and enjoys a long lifespan.

Specification

Material	carbon steel, stainless steel
Hole pattern	diamond
Opening size	23 mm × 50 mm
Thickness	2 mm – 3 mm
Open area	76%–79%
Load capacity	55–65 kg/m ²
Surface treatment	hot dip galvanized, zinc content 500 g/m ²

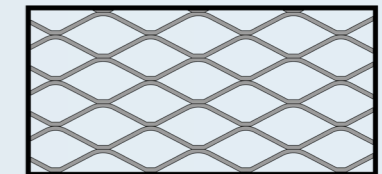

3/4" #13 Flattened

Gallery



DECORATION



Our decorative expanded metal comes in a variety of materials, hole patterns and colors, and perfectly combines the aesthetics and functions together. As a result, it becomes a popular modern building decorative material. It has been widely used in facades, ceilings, sunshades, interior decoration, handrails, etc. our designers and engineering team will make out best custom expanded metal solutions for you according to your requirements.



Facade

Expanded metal facade is a lightweight wall commonly used in modern large-scale or high-rise buildings to protect and decorate exterior walls. Decorative expanded metal is a popular facade material with extensive hole patterns and diversified colors and is widely used in shopping malls, commercial buildings, hotels, parking lots and other public buildings.

Expanded metal facade is generally made of 3 mm – 5 mm thick aluminum plate, lightweight and sturdy. Expanded metal with anodized or PVDF coated finish not only has attractive appearance, but also delivers excellent weather resistance and a long lifespan. As a result, it gains an ever-increasing popularity among architects and designers



Recommended Expanded Metal Facade Specification

Material	Thickness (mm)	Strand Width (mm)	SWD (mm)	LWD (mm)	Recommended Size: Width x Length (mm)		Remarks
					Size 1	Size 2	
Aluminum	2, 2.5, 3	8, 9, 10	34	75	1220 x 2000	2400x1200	
	2, 2.5, 3	8, 9, 10	40	48	1220 x 2000	2400x1200	
	2, 2.5, 3	10, 12, 15	50	110	1220 x 2000	2400 x 1200	
	2, 2.5, 3	16, 18, 20	63	150	1220 x 2000	2400 x 1200	
	2, 2.5, 3	25, 28, 30	80	200	1220 x 2000	2400 x 1200	Hexagonal (knuckle about 40 mm)
	2, 2.5, 3	25, 28, 30	95	250	1220 x 2000	2400 x 1200	
	2, 2.5, 3	25, 28, 30	95	300	1220 x 2000	2400 x 1200	

- Frame size: aluminum angle: 30 x 30 x 2 mm and above; for large size, 3 mm thickness is recommended; the large the frame, the thicker the aluminum angle.
- Other sizes are available upon request.

Features

- **Lightweight yet sturdy structure.** It reliefs the burden of exterior walls and can withstand harsh weather erosion.
- **Ventilation.** Uniform opening allows the free passage of light and air.
- **Modern decoration style.** Come in a variety of hole patterns and colors and bring unique decoration effects for buildings.
- **Long service life.** Anodized or PVDF coated finish, corrosion resistance and UV resistance.
- **Easy installation and maintenance-free.**

Gallery



Exhibition



Shopping mall



Parking lot



Office building

Ceiling

Expanded metal ceiling is one of indispensable materials in modern building design. It not only brings amazing visual effect, but also delivers fireproof, heat insulation, noise absorption and other practical functions. It is widely used in offices, libraries, shopping malls, airports, railway stations and other public buildings.

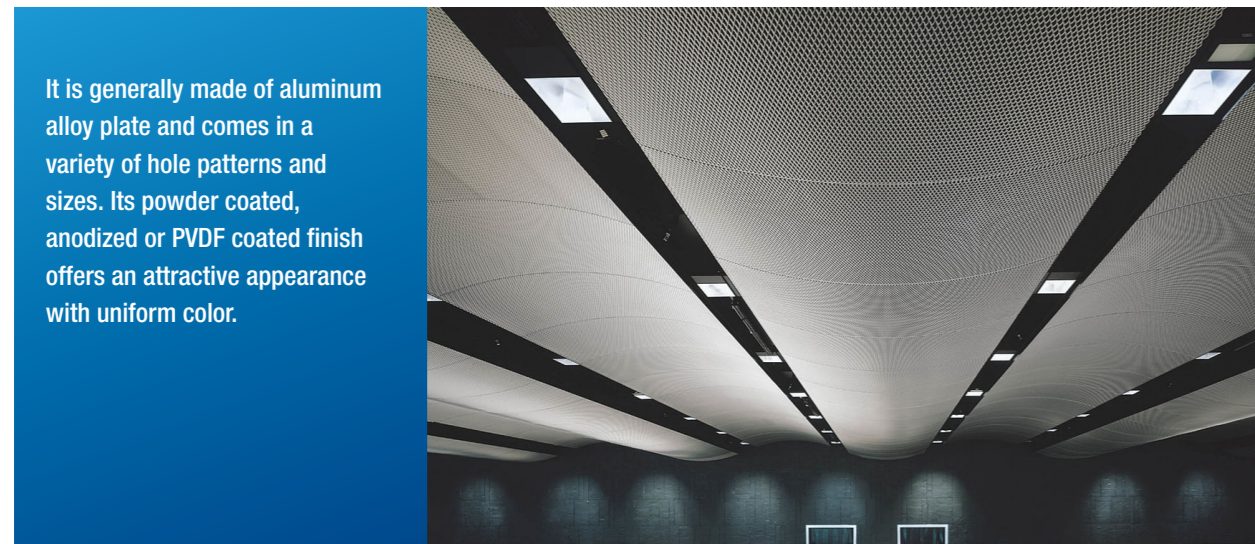

It is generally made of aluminum alloy plate and comes in a variety of hole patterns and sizes. Its powder coated, anodized or PVDF coated finish offers an attractive appearance with uniform color.

Features

Expanded metal not only brings new, unique visual effect, but also has the following functional advantages:

- **Fireproof.** Aluminum and stainless steel expanded metal has natural fireproof property and complies with Code of Practice for Fire Safety in Buildings.
- **Beautiful & safe.** During installation, certain gap should be left to house ventilation ducts, sprinkler systems and circuits, which not only provides a beautiful appearance, but also creates an air vent to ensure indoor security
- **Flexible & versatile.** The specification of the expanded metal can be tailored to achieve the optimum level of diffused lighting.
- **Heat insulation.** Excellent heat insulation helps to reduce the cost of indoor air conditioning systems.
- **Sound absorption.** Good sound absorption helps to reduce the noise in the room.
- **Easy to install and remove.** Hang-in systems are used for installation, easy to install and remove and facilitate roof system maintenance.

Hole Pattern

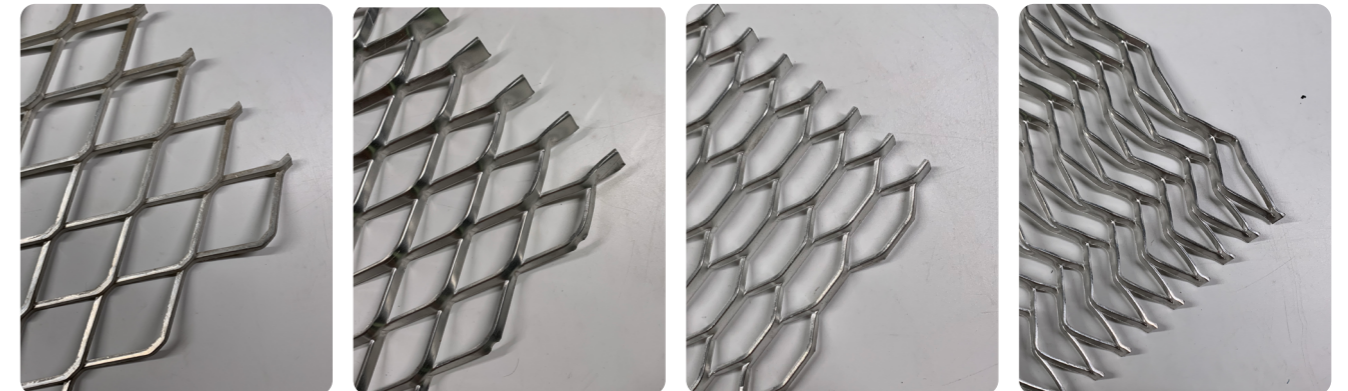

Diamond

Fan-shaped

Hexagonal

Special-shaped

Specification

Material	Thickness (mm)	Strand Width (mm)	SWD (mm)	LWD (mm)	Recommended Size: Width x Length (mm)		Remarks
					Size 1	Size 2	
Aluminum	1.5, 2	2, 2.5	10	20	1000 x 2000	1200 x 2000	
	1.5, 2	2, 2.5	14	20	1000 x 2000	1200 x 2000	
	1.5, 2	2, 2.5	12	25	1000 x 2000	1200 x 2000	
	1.5, 2	2, 2.5, 3	15	30	1000 x 2000	1200 x 2000	
	1.5, 2	2.5, 3, 4	17	40	1000 x 2000	1200 x 2000	
	1.5, 2, 2.5, 3	4, 5	22	40	1000 x 2000	1200 x 2000	
	2, 2.5, 3	5, 6, 7	25	60	1000 x 2000	1200 x 2000	
	2, 2.5, 3	5, 6, 7	30	60	1000 x 2000	1200 x 2000	
	2, 2.5, 3	3.5, 4	16.5	60	1000 x 2000	1200 x 2000	Hexagonal (knuckle about 20 mm)

- Other sizes are available upon request.
- For larger sizes, reinforcement is required to prevent expanded metal panels from sagging.
- For expanded metal panel with mesh bending frame, the mesh width shall be equal to the panel width; for expanded metal panel with angle steel frames, bending shall be considered, so the mesh width shall be 4-5 cm smaller than the panel width.
- Frame size: aluminum angle: 30 x 30 x 2 mm (thickness); hang-in angle: 30 x 30 x 2 mm (thickness); for panels larger than 1200 x 2000 mm, 3 mm thick is recommended.

Gallery

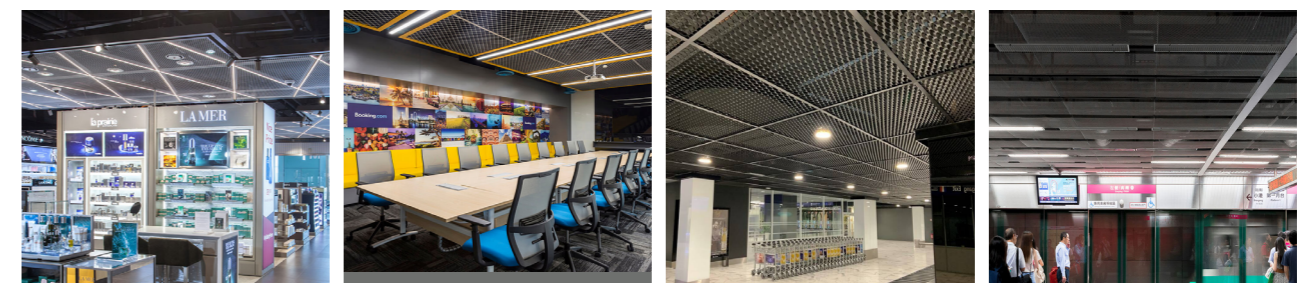

Shop

Office

Airport

Subway

Sunshade

Air conditioning systems are usually provided inside the building to create a comfortable indoor environment. However, these systems often consume a lot of energy, so expanded metal sunshades are often installed in modern buildings to reduce energy consumption. Expanded metal is an innovative sunshade material made of aluminum plate that has been slit and stretched. Its special 3D structure can effectively block strong, dazzling sunlight, and its uniform openings allow the free passage of fresh air, thus creating a cooler and more comfortable environment for people inside the building.

Expanded metal sunshades are widely used in residential buildings, office buildings, stadiums, shopping centers, etc.

As the sun rises in the sky, the light passing through the expanded metal varies as the angle of light changes. When the sun reaches a certain angle, the strand width creates the maximum shadow area. At this time, the mesh opening can maximize the indoor daylight and air flow and make the room bright and cool. This shading effect is similar to the principle of the louver.

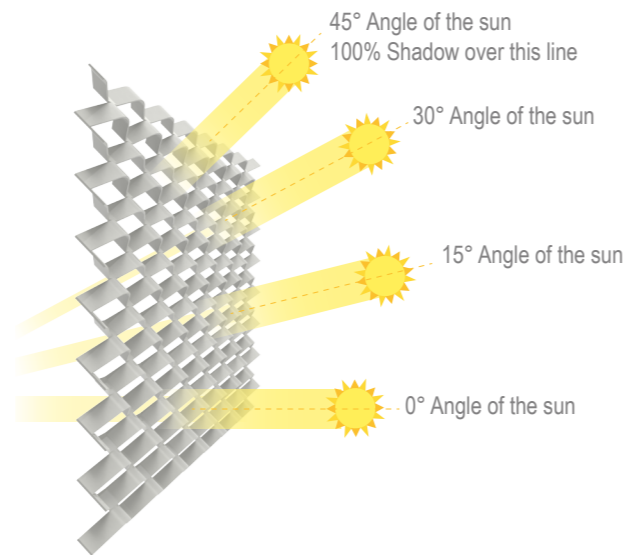
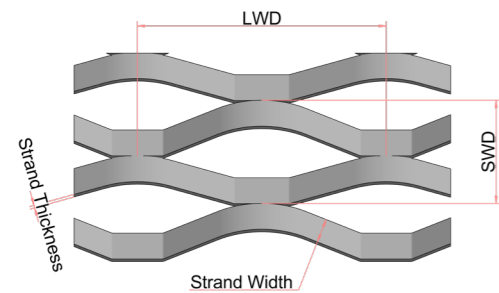

Material	Opening Size (mm)		Strand (mm)		Open Area	Panel Size (L x W) (mm)
	SWD	LWD	Strand Width	Strand Thickness		
Aluminum	26	70	11	2	26%	1000 x 2000
	48	115	20	2	58%	1250 x 2500
	80	200	24	2	80%	1500 x 3000

Gallery



Apartment

Residential buildings

Stadium

Office buildings

Interior Decoration

Interior design concerns the combination of material aesthetic and practical functions. Expanded metal interior decoration comes in a variety of hole patterns, colors and sizes. As a result, it not only brings you stunning interior decoration effects, but also achieves division, support and protection functions. It is widely used in interior partition, shop show window, background wall, lamp decoration, etc.



Billboard background



Shop decorative wall



Show shelves



Fitness room partition



Hotel interior partition



Folding screen



Bar counter decoration



Goods exhibition & decoration

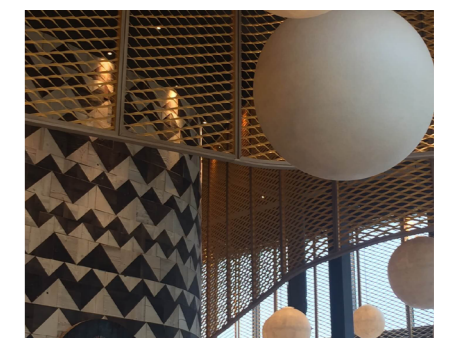

Ceiling decoration

Handrails

Expanded metal handrails are robust and durable and are commonly used as stair rails or balcony rails. It can not only play the role of security protection, but also can perfect fit for different architecture styles as it comes in a variety of hole patterns, colors and sizes.

Our expanded metal products are provided with powder coated or anodized finishes to offer excellent corrosion resistance and ensure it enjoy a long lifespan no matter in indoor or outdoor applications.



Features

- Unique, attractive appearance gives a great decoration effect.
- High strength and good impact resistance ensure high security.
- Uniform openings allow the free passage of air and light.
- Corrosion resistant surface treatment, sturdy and durable.
- Easy installation and maintenance-free.

Specification

Material	aluminum, stainless steel, carbon steel
Thickness	1.5 mm – 3 mm
LWD	12.5 – 200 mm
SWD	5-80 mm
Panel size	1000 mm × 2000 mm, 1250 mm × 2500 mm (standard size), other sizes are available upon request.
Finish	galvanized, PVDF coated, anodized, etc.

Hole Pattern

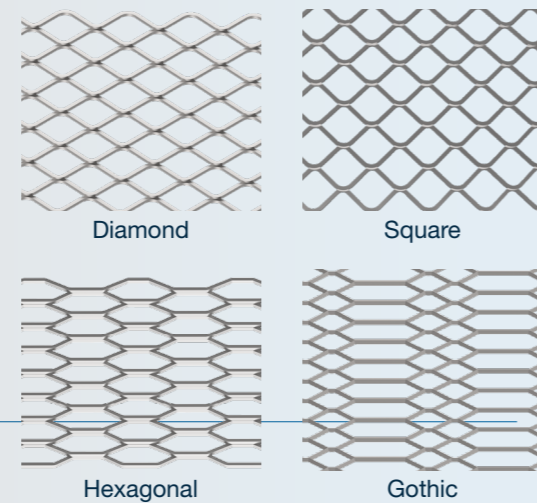

Gallery



Balcony rails

Indoor stair rails

Outdoor balustrade

Outdoor stair rails

FILTRATION



Small hole expanded metal can not only protect and support non-woven fabrics, filter paper and other filter media, but also can act as a main filter material to remove impurities. It is an ideal choice for the filtration industry and is widely used in air filtration, process water treatment, paint filtration, grease filtration and other fields.

Expanded metal for filtration is generally made of small hole expanded metal. It can be made into conical, pleated, cylindrical and other shapes through advanced forming process to meet the demands of various filtration applications.

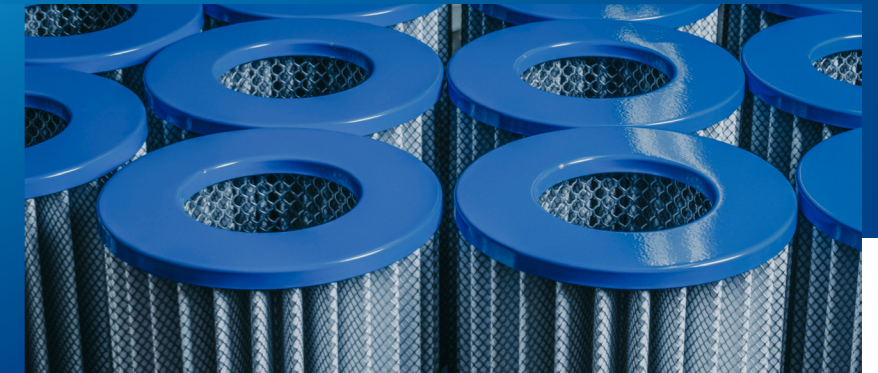

Features

- **Economical & eco-friendly.** Expanded metal is constructed through slitting and stretching, no material is wasted during the production, and is a perfect alternative to perforated metal.
- **Sturdy & durable.** When the air or liquid passes through the filter elements at high working pressure, the support layer is sturdy and not easy to loose.
- **Precise filtration.** Expanded metal opening sizes can be customized according to your desired filter rating to effectively remove specified solid particles.
- **Corrosion resistance.** Hot dip galvanized expanded metal surface make it not easy to rust in acid and alkali filtration environments.

Specification

Material	Opening Size (mm)		Strand (mm)		Panel Size (L × W) (mm)
	SWD	LWD	Strand Width	Strand Thickness	
Stainless steel, aluminum, copper, titanium	4	8	0.8	0.8	60%
	6	12	0.8	0.8	73.3%
	7	14	0.8	0.8	77.1%
	6	12	1.0	1.0	67%
	7	14	1.0	1.0	86%

Gallery

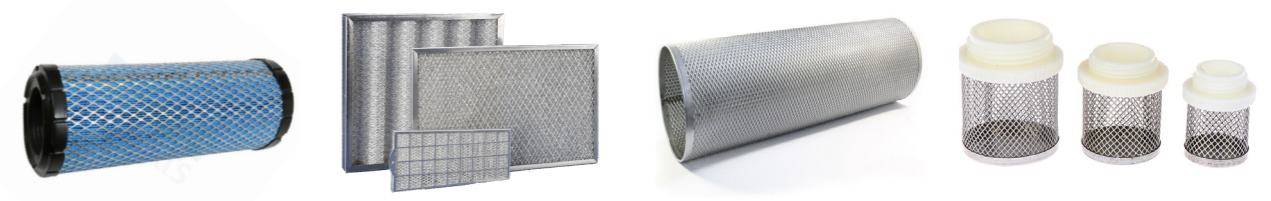

Air filter

Metal filter

Filter cylinder

Custom filter elements

AUTOMOBILE



Expanded metal often serves as inlet grilles, pickup headache racks, speaker grills and other automobile parts and its rigid structure can protect the key part well. We can supply expanded metal for automobile to meet the needs of various automobile applications.

Automobile Inlet Grilles

Automobile, especially commercial cars and high performance racing cars, their inlet grilles are usually constructed of aluminum expanded metal. Its uniform, small openings can prevent debris and small particles from entering the engine compartment. At the same time, it allows the air to flow into the engine, providing good heat dissipation.

- Material: aluminum alloy
- Hole pattern: diamond, hexagonal, square
- Opening size: 5 × 10 mm, 7 × 12 mm, 8 × 16 mm, 10 × 20 mm, 7 × 25 mm, 8 × 25 mm
- Finish: powder coated, anodized



Pickup Headache Rack

It is usually made of durable expanded metal sheet. Its unique opening structure not only provides an excellent rear view for drivers, but also delivers great impact resistance. In addition, it is available in a variety of colors to perfectly match with your pickup body.

- Material: aluminum
- Hole pattern: diamond, hexagonal
- Opening size: 24 × 48 mm
- Finish: powder coated



Speaker Grill

Automobile speaker grill is typically constructed of flattened small hole expanded metal to protect the internal drive elements in the speaker from external shocks while providing great acoustics and decoration effects.

- Material: carbon steel
- Thickness: 0.5 mm
- Hole pattern: diamond
- Opening size (SWD × LWD): 1.5 × 2.5 mm, 1.7 × 2.8 mm, 2.1 × 3 mm
- Finish: powder coated



MORE



Expanded metal is a versatile metal material and is widely used in security & protection, construction, engineering, decoration and other fields. We can see expanded metal applications everywhere in our life. It provides great security protection and convenient conditions for our life. For more expanded metal applications, please see the following examples.

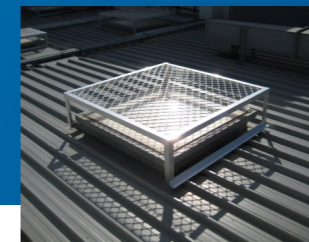

Skylight guards



Chimney cap



Fireplace screen



Grill tray



Storage cabinet



Trailer tool cabinet



Shelf decking



Drying plate



Radiator cover



Outdoor desk & chair

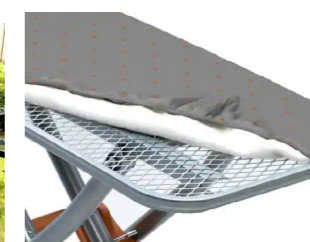

Ironing board

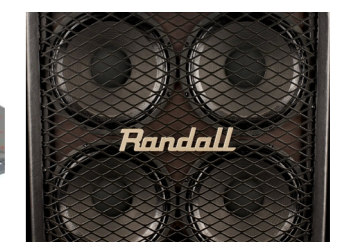

Speaker grill



Bicycle basket



Trash can



Slope ramp



Multi-function step ladder



Trailer ramp



Dock decking

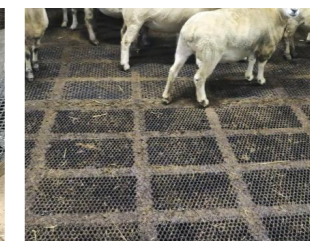

Animal flooring





MADE-TO-ORDER

Expanded metal is a versatile product, and its manufacturing requirements vary as application environment changes, for example, material, hole pattern, size and finish. Our professional R&D team have years of experience in expanded metal product development and project applications, and can make out the best custom expanded metal solutions according to your application environment.

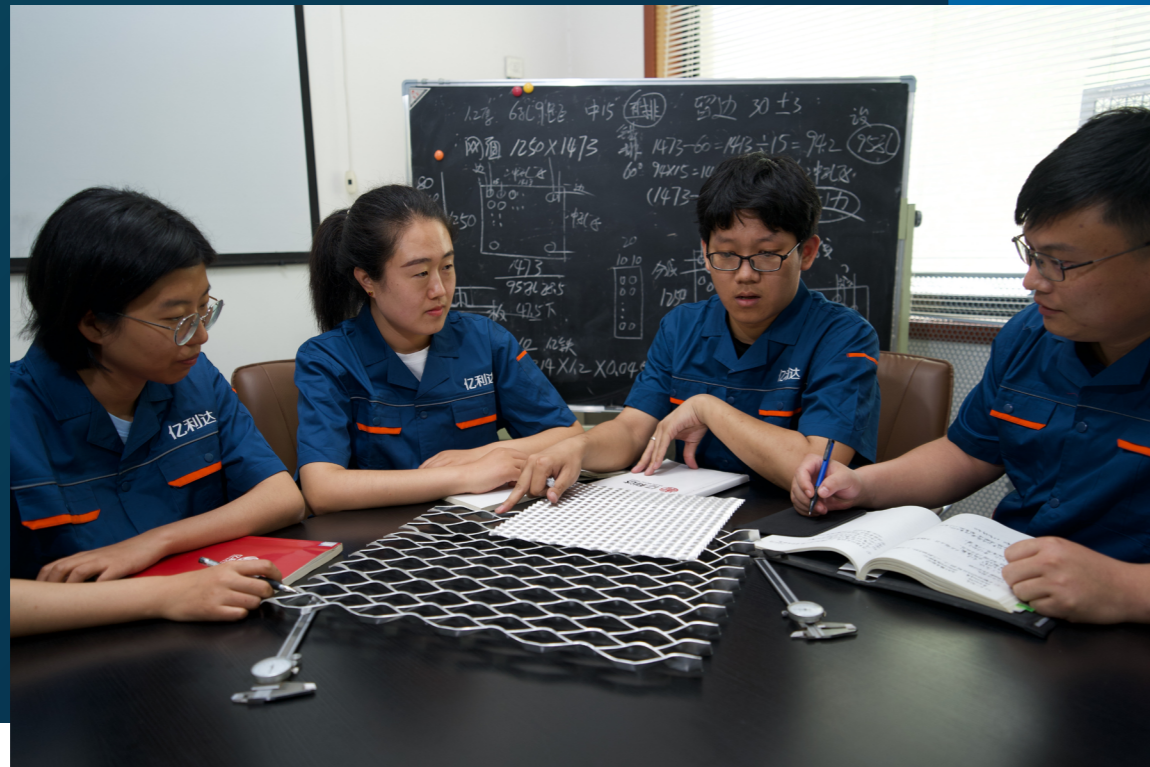

Custom Materials

Expanded metal used in different application environments will have special requirements for its materials. For example, walkways and stair treads are generally constructed of carbon steel expanded metal to meet its load bearing requirements; while building decoration and automobile typically adopt aluminum expanded metal, lighter and aesthetic. We will choose the right material expanded metal according to your application environments to meet your specific requirements

- Carbon steel Q195, Q235, Q345, SPHC, A36
- Aluminum
 - 1# aluminum sheet 1060, 1050, 1100
 - 3# aluminum sheet 3003
 - 5# aluminum sheet 5005, 5052
- Stainless steel 304, 316L
- Copper
- Nickel
- Titanium.

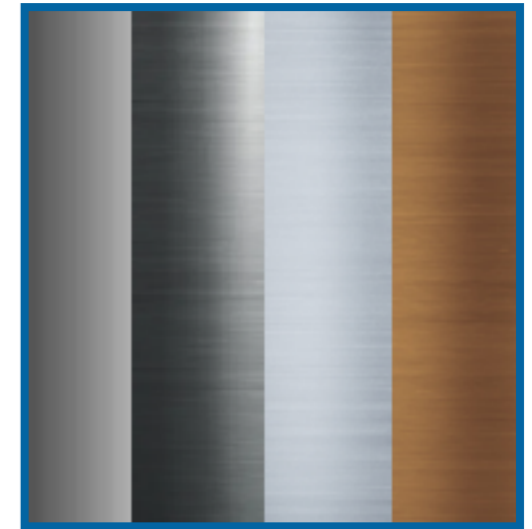

Custom Hole Patterns

Currently, we have independently developed and accumulated more than 500 kinds of precise expanded metal moulds. We are familiar with the application of every hole pattern and can select or developed expanded metal with new hole patterns according to your specific application to meet your requirements in load capacity, aesthetic, ventilation, sun shading and other aspects.

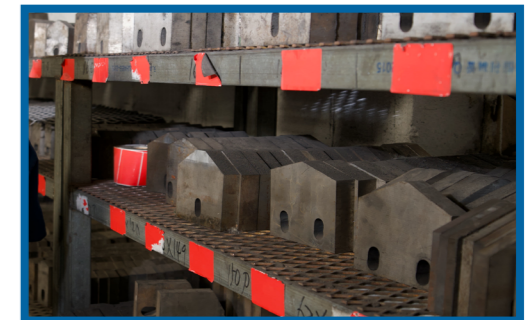

Custom Processing & Manufacturing Services

We have cutting, bending, welding and other deep processing equipment. We have full capacity to provide specified deep processing and manufacturing services for your expanded metal products to meet your specific requirements.

Custom expanded metal processing and manufacturing services include:

- Flattening
- Leveling
- Cutting
- Bending
- Welding
- Framing
- Powder coated
- Anodized
- PVDF coated



Custom Installation Scheme

Our professional team will design the best installation scheme according to your specific application project. In addition, we can provide online installation technical guidance to help you install your expanded metal correctly and quickly.



EXPANDED METAL

ADVANCED EXPANDED METAL
MANUFACTURER
& SOLUTION PROVIDER

Anping Yilida Metal Wire Mesh Co., Ltd

Address: Wire Mesh Development Zone, Anping County, Hengshui City, Hebei Province, China. 053600

Tel: +86-13932824722

Whatsapp: +86-311-89948200

Email: inquiry@wiremesh-yld.cn

<https://www.yld-wiremesh.com>

